

Top mounted shutter

CC1000®

TL1000®

TECHNICAL CATALOGUE



TABLE OF CONTENTS:

Features and benefits of the CC1000, TL1000 systems	2
Box components	3
Sections and parts list CC1000	4
Sections and parts list TL1000	10
Sides	14
Adaptation profiles	17
PVC profiles	19
Styrofoam inserts	23
Steel, aluminium components	25
Accessories	30
Curtain profiles, profile plugs	38
Bottom laths, additional components of the bottom lath	39
PVC spacers and guides	41
Divisions	42
Assembly drawings - divisions	44
Assembly drawings - entry of the tape	51
Assembly drawings - inspection covers	52
Assembly drawings - crank lifting mechanism	53
Assembly drawings - NHK installation	56
Assembly drawings - installation of the stabilizing console system-TL1000	60
Assembly drawings - installation of the motor	62
Assembly drawings - installation of PVC guides	64
Recommended box sizes	65
Certificates	67



CC1000[®]

the simplest solution in
technical and economic
terms

small shutter box - more
light in your interior

It works perfectly in thin walls



TL1000[®]

solution tested for many
years - reliability
and satisfaction

reasonable quality-
price ratio

perfectly matched to the conditions
of the Polish installation



*CC1000, TL1000 are trademarks of PORTOS.
All photos and drawings contained in the catalogue are for reference only.
The PORTOS company reserves the right to make changes.
©2023 PORTOS. All rights reserved.*

CC1000[®]

TL1000[®]

LEGEND:



The system to which, the component is intended.



The size of the box for which the component is intended.



The indicative weight of the component (in kilograms).



Maximum length of a long component (given in meters).



The material used to make a component (e.g. PVC, ASA, etc.).



It contains no harmful heavy metals such as lead.



The component with a veneering option.

Components of the CC1000® system Box 135 - cross-section and parts list

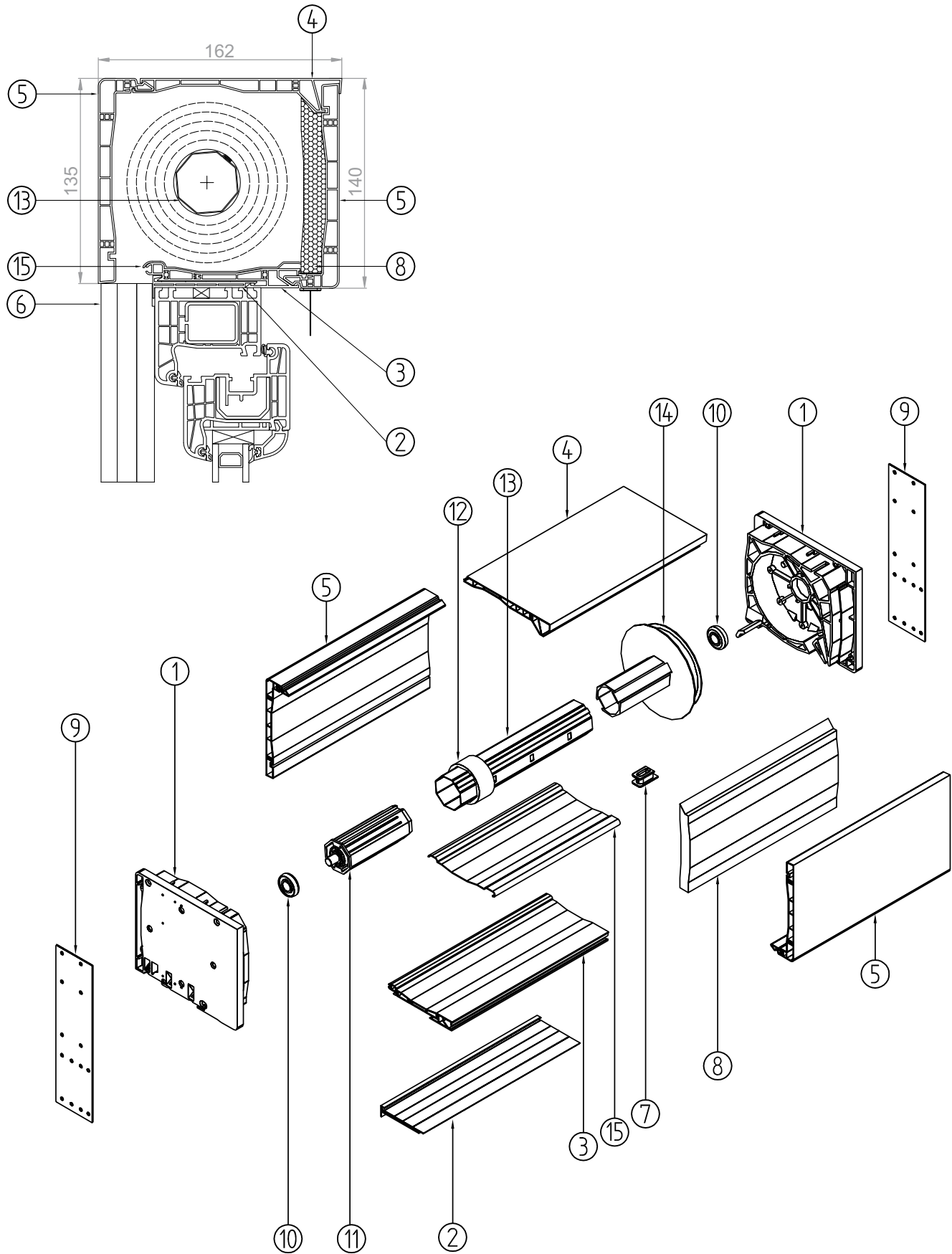

CC1000[®] box 135 - cross-section and parts list

1	RF100	Side of the box 135
2	RN	Adaptation profile
3	RK2	Mounting profile of the box 135, 160, 200
4	RK3	Top profile of the box 135, 160, 200
5	RK40	Inner and outer cover of the box 135
6	RK-16	Single guide
7	E-R265	Belt guide
8	RW1	Thermal insulation of the box 135
9	RKZ66	Steel side handle for box
10	LO 28/10	Bearing 28/10 for PVC
	LO 28/12 PCV	Bearing 28/12 for PVC
11	OBS-40-PCV	40 mounting for PVC with pin
	OBS-60-PCV	60 mounting for PVC with pin
12	PZ40/50	Expansion ring
	PZ60/70	Expansion ring
13	SW 40	Octagonal pipe ø 40
	SW 60	Octagonal pipe ø 60
14	RKZ70	Winding wheel for box 135
15	RA-10	Steel box reinforcement 135, 160, 200 - large

Components of the CC1000® system Box 160 - cross-section and parts list

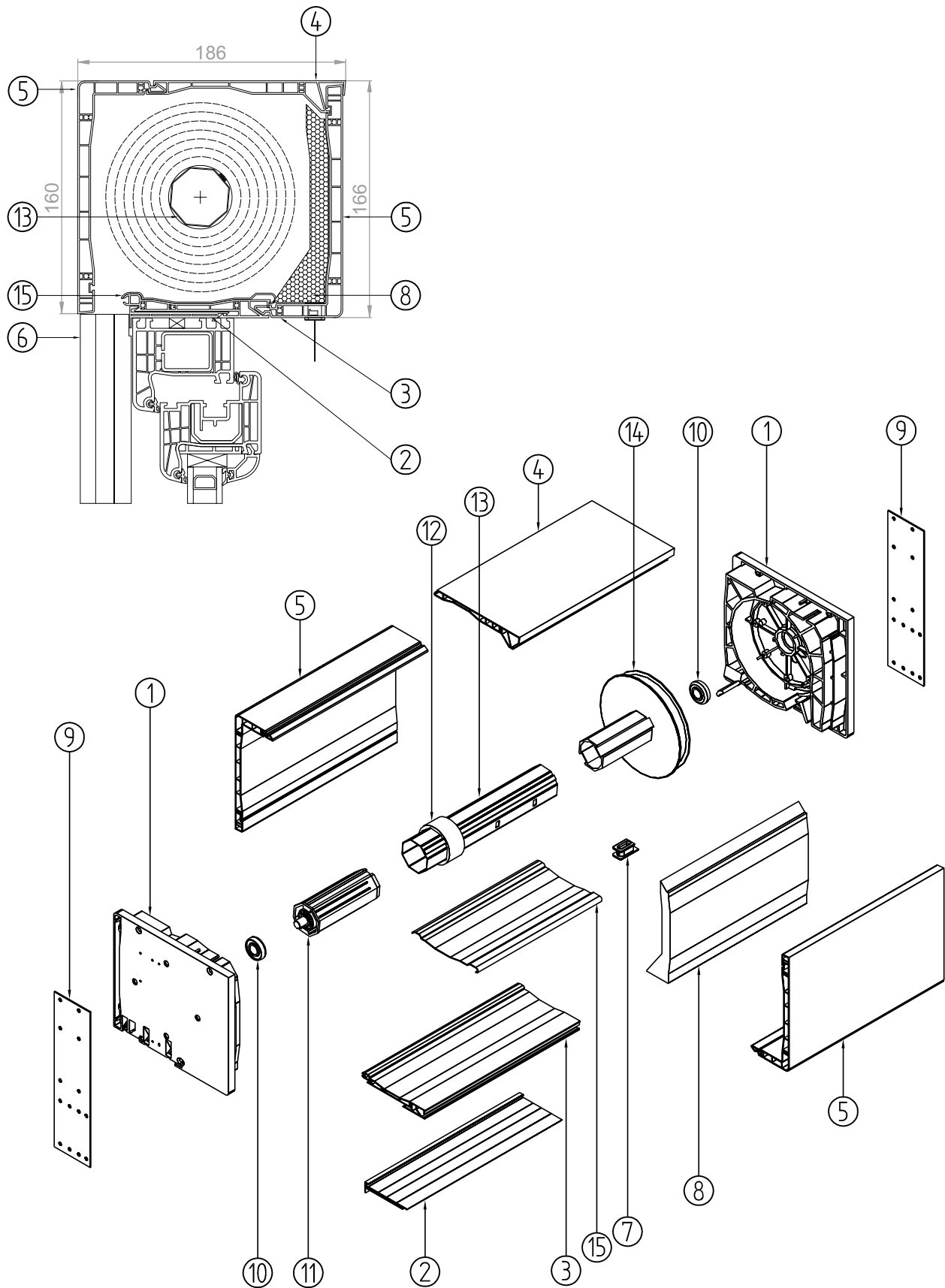

CC1000[®] box 160 - cross-section and parts list

1	RF200	Side of the box 160
2	RN	Adaptation profile
3	RK2	Mounting profile of the box 135, 160, 200
4	RK3	Top profile of the box 135, 160, 200
5	RK50	Outer cover of the box 160
	RK50 R	Outer cover of the box 160 - grooved
6	RK-16	Single guide
7	E-R265	Belt guide
8	RW2	Thermal insulation of the box 160
9	RKZ66	Steel side handle for box
10	LO28/10	Bearing 28/10 for PVC
	LO28/12 PCV	Bearing 28/12 for PVC
11	OBS-40-PCV	40 mounting for PVC with pin
	OBS-60-PCV	60 mounting for PVC with pin
12	PZ40/50	Expansion ring
	PZ60/70	Expansion ring
13	SW 40	Octagonal pipe \varnothing 40
	SW 60	Octagonal pipe \varnothing 60
14	RKZ71	Winding wheel for box 160
15	RA-10	Steel box reinforcement 135, 160, 200 - large

Components of the CC1000® system Box 200 - cross-section and parts list

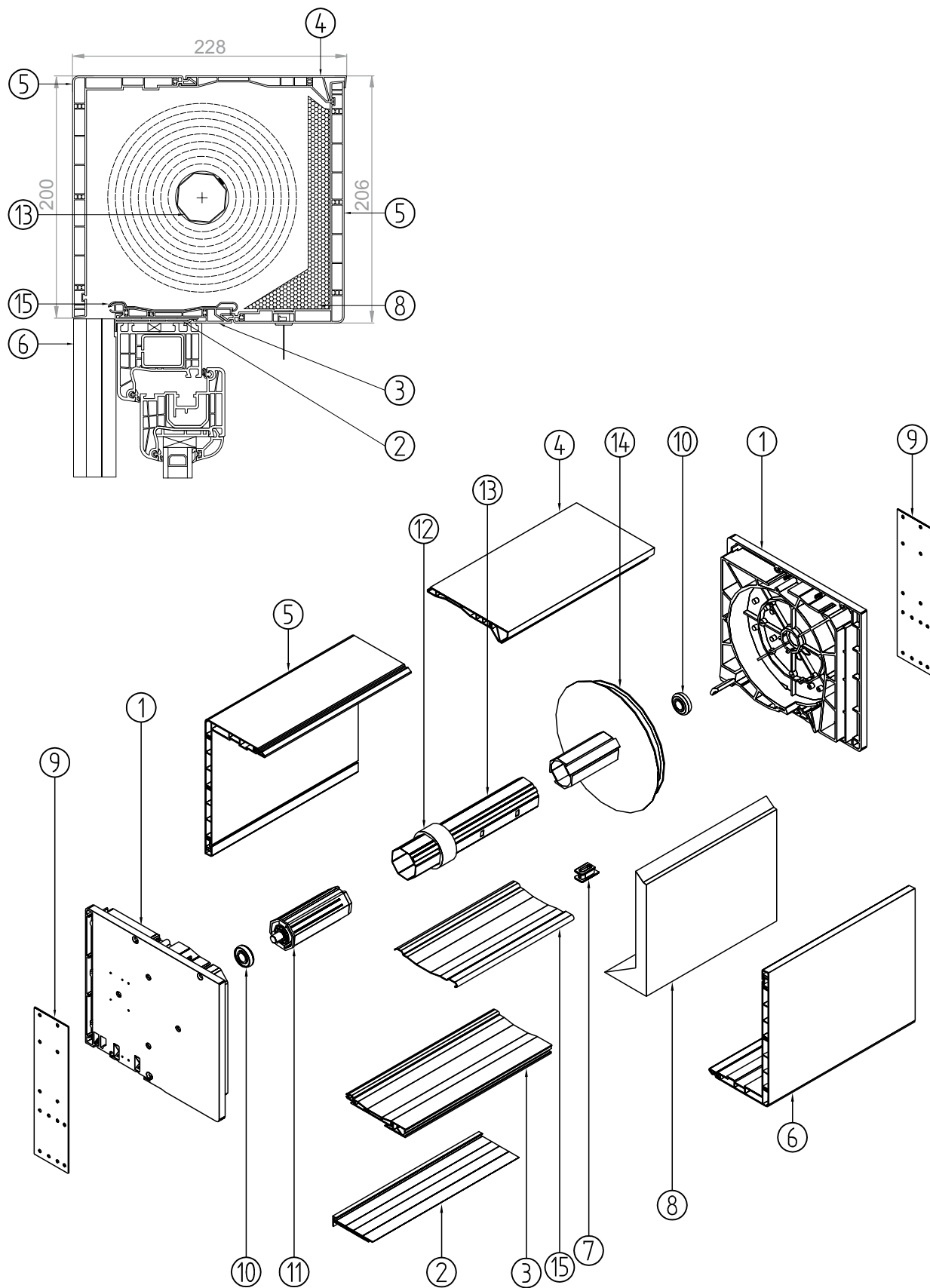

CC1000[®] box 200 - cross-section and parts list

1	RF300	Side of the box 200
2	RN	Adaptation profile
3	RK2	Mounting profile of the box 135, 160, 200
4	RK3	Top profile of the box 135, 160, 200
5	RK60	Outer cover of the box 200
	RK60 R	Outer cover of the box 200 - grooved
6	RK-16	Single guide
7	E-R265	Belt guide
8	RW3	Thermal insulation of the box 200
9	RKZ66	Steel side handle for box
10	LO28/10	Bearing 28/10 for PVC
	LO28/12 PCV	Bearing 28/12 for PVC
11	OBS-40-PCV	40 mounting for PVC with pin
	OBS-60-PCV	60 mounting for PVC with pin
12	PZ40/50	Expansion ring
	PZ60/70	Expansion ring
13	SW 40	Octagonal pipe \varnothing 40
	SW 60	Octagonal pipe \varnothing 60
14	RKZ72	Winding wheel for box 200
15	RA-10	Steel box reinforcement 135, 160, 200 - large

Components of the TL1000® system Box 160 - cross-section and parts list

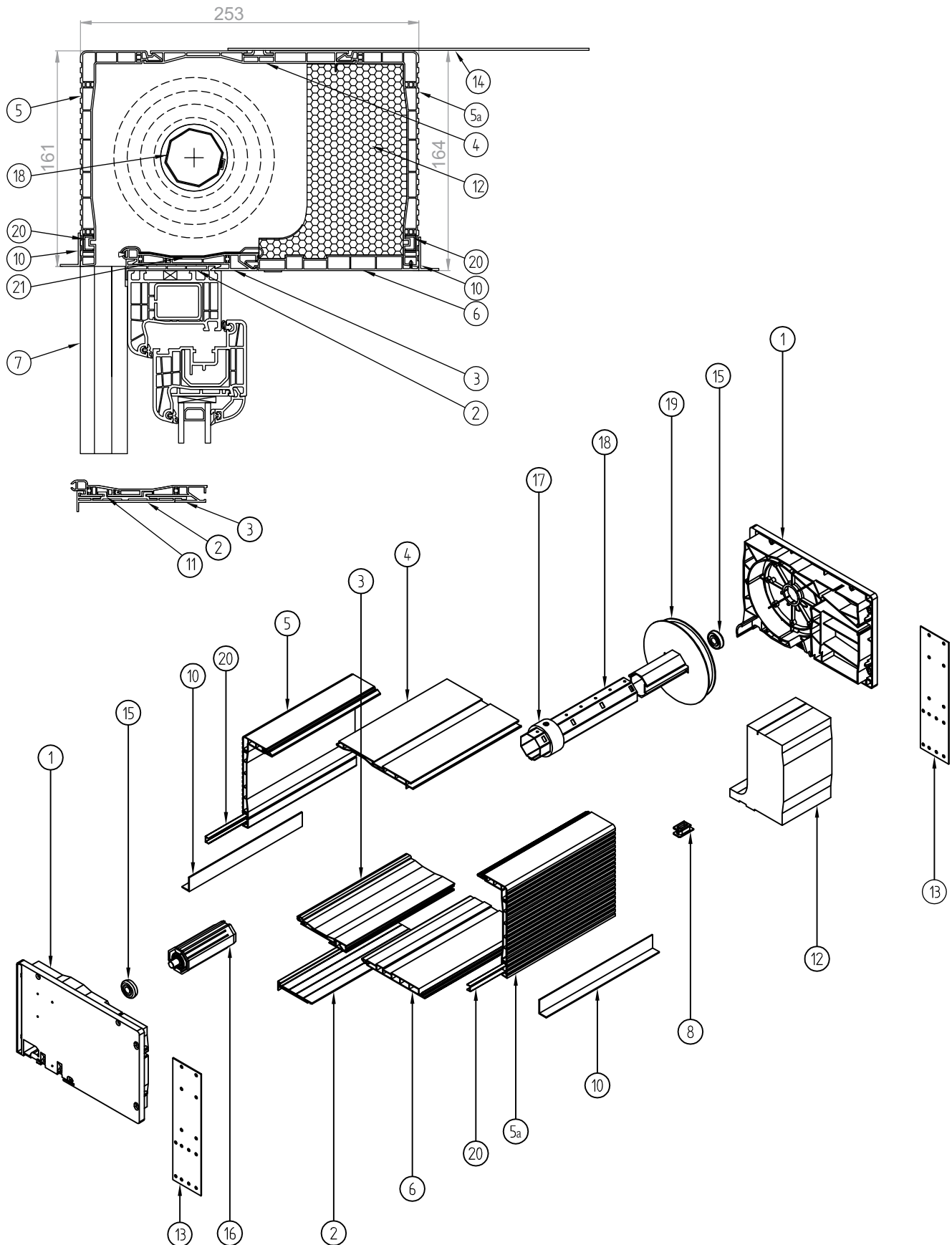

TL1000[®] box 160 - cross-section and parts list

1	BPRM 200	Side of the box 160
2	RN	Universal adaptation profile
	RN1-70 B	Universal adaptation profile 70 mm
3	RK2-70	Mounting profile of the box 160, 200
4	PGL 1-K	Top profile of the box
5	RK50	Profile of the box 160 side
	RK50 R	Profile of the box 160 side grooved
5a	RKT50	Inner cover of the box 160
	RKTR50	Inner cover of the box 160 - grooved
6	PKL1	Inspection cover of the box 160, 200
7	RK-16	Single guide
8	E-R265	Belt guide
10	LT	Concealed lath
11	NPL-020	Adapter aluminium insert
12	BPRN 200	Styrofoam insert of the box 160
13	RKZ66	Steel side handles
14	SKM-TL1000	Steel mounting anchor
15	LO 28/10	Bearing 28/10 for PVC
	LO28/12 PCV	Bearing 28/12 for PVC
16	OBS-40-PCV	40 mounting for PVC with pin
	OBS-60-PCV	60 mounting for PVC with pin
17	PZ40/50	Expansion ring
	PZ60/70	Expansion ring
18	SW 40	Octagonal pipe \varnothing 40
	SW 60	Octagonal pipe \varnothing 60
19	RKZ71	Winding wheel for box 160
20	RA-2-00 7 MM	Steel box reinforcement 160, 200 - small
21	RA-10	Steel box reinforcement 135, 160, 200 - large

Components of the TL1000® system Box 200 - cross-section and parts list

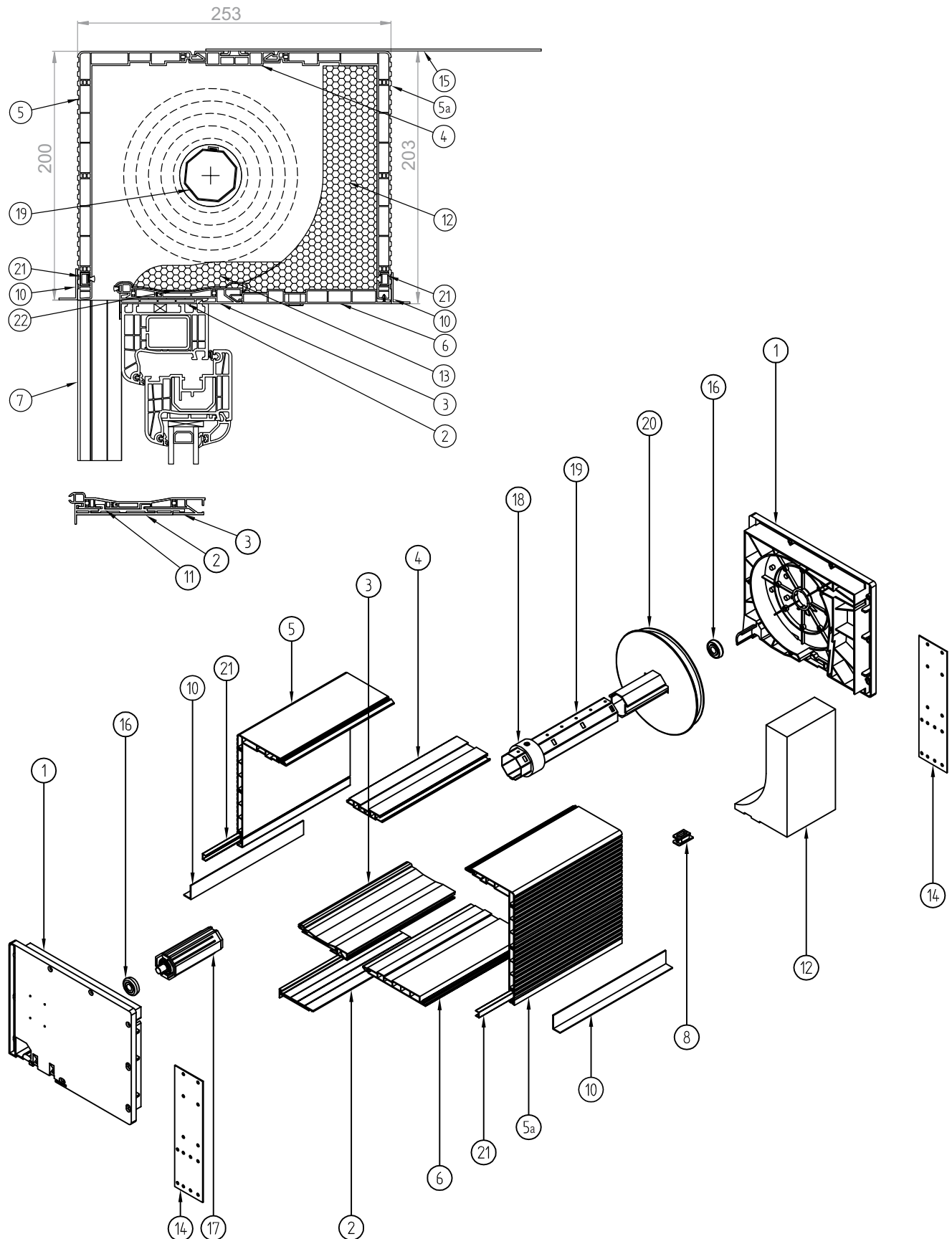

TL1000[®] box 200 - cross-section and parts list

1	BPRM 300	Side of the box 200
2	RN1	Universal adaptation profile
	RN1-70	Universal adaptation profile 70 mm
3	RK2-70	Mounting profile of the box 160, 200
4	PGL 2-K	Top profile of the box
5	RK60	Profile of the box 200 side
	RK60 R	Profile of the box 200 side grooved
5a	RKT60	Inner cover of the box 200
	RKTR60	Inner cover of the box 200 - grooved
6	PKL1	Inspection cover of the box 160, 200
7	RK-16	Single guide
8	E-R265	Belt guide
10	LT	Concealed lath
11	NPL-020	Adapter aluminium insert
12	BPRN 300	Styrofoam insert of the box 200
13	BPRN 300 2/S	Bottom styrofoam insert of the box 200
14	RKZ66	Steel side handles
15	SKM-TL1000	Steel mounting anchor
16	LO 28/10	Bearing 28/10 for PVC
	LO28/12 PCV	Bearing 28/12 for PVC
17	OBS-40-PCV	40 mounting for PVC with pin
	OBS-60-PCV	60 mounting for PVC with pin
18	PZ40/50	Expansion ring
	PZ60/70	Expansion ring
19	SW 40	Octagonal pipe \varnothing 40
	SW 60	Octagonal pipe \varnothing 60
20	RKZ72	Winding wheel for box 200
21	RA-2-00 7 MM	Steel box reinforcement 160, 200 - small
22	RA-10	Steel box reinforcement 135, 160, 200 - large

Components of the CC1000® system Box 135, 160 - sides

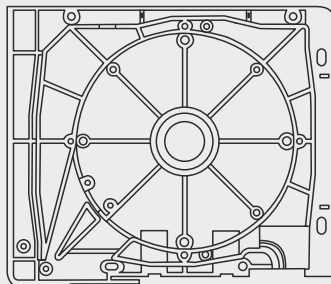
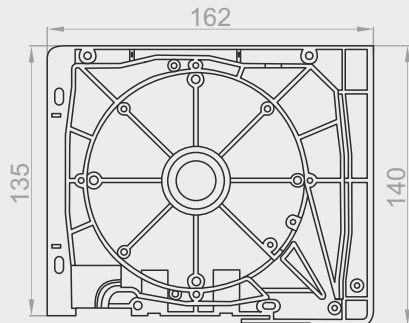

RF100 L

Side of the box 135 left

RF100 P

Side of the box 135 right

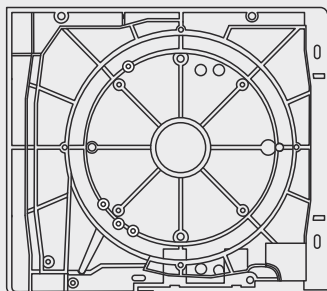
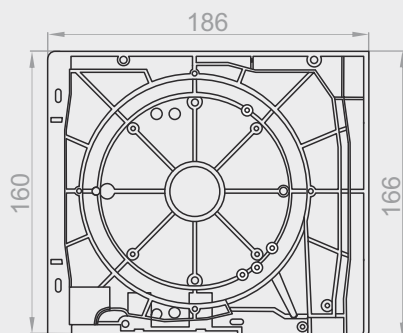

RF200 L

Side of the box 160 left

RF200 P

Side of the box 160 right



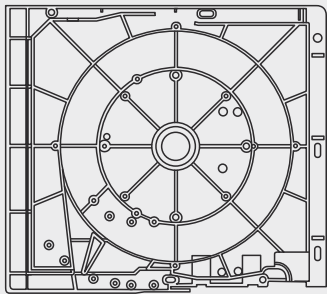
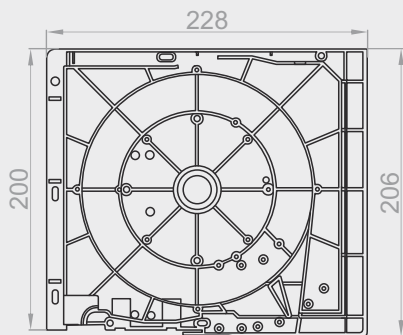

RF300 L

Side of the box 200 left

RF300 P

Side of the box 200 right



Components of the TL1000® system
Box 160, 200 - sides

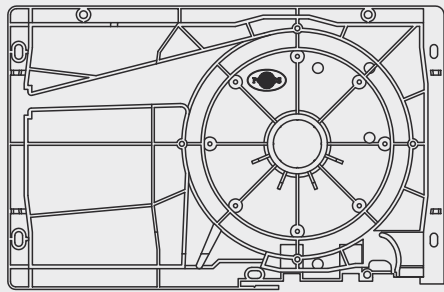
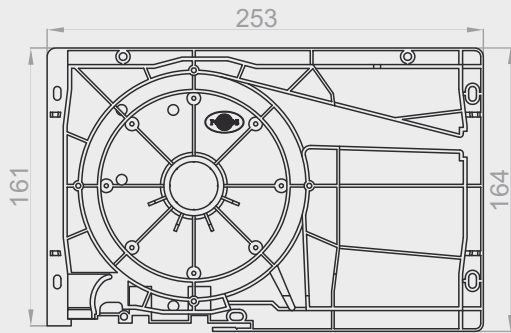

BPRM 200 L

Side of the box 160 left

BPRM 200 P

Side of the box 160 right

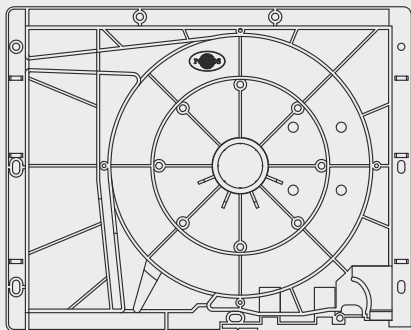
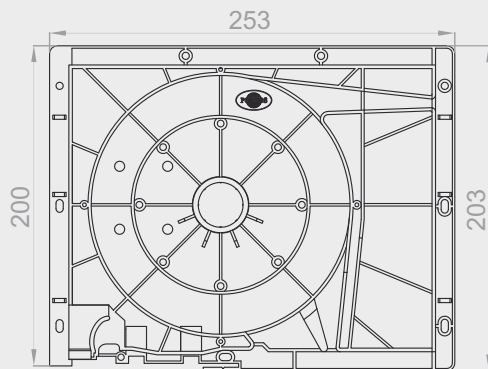

BPRM 300 L

Side of the box 200 left

BPRM 300 P

Side of the box 200 right



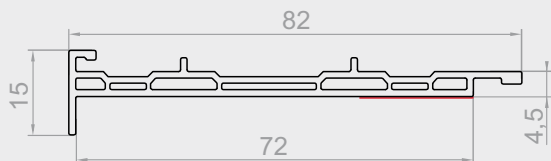

RN 1-70 B

Universal adaptation profile
For window profiles:

Kömmerling (EuroFutur Classic 70mm, Elegance 70mm, MD Classic 70mm, MD Classic półzłocowany 70mm)
KBE (System z uszczelką przylegową 58mm, 70mm)
Rehau (Geneo 86mm)
Oknoplast Kraków (70mm)
Schüco (Corona CT 70 70mm)
Salamander (Salamander 3D 76mm, SL 76mm, Vision 76mm)
Deceuninck (Zendów 3k 70mm, projekt 3000 70mm)
Deceuninck - Thyssen (Prestige 76mm, Prestige Passiv-Haus 76mm)
Wymar (Wymar 60 60mm, Wymar 72 70mm)
Decco (7010 70mm)
Brüggmann (AD 73mm, MD 73mm)

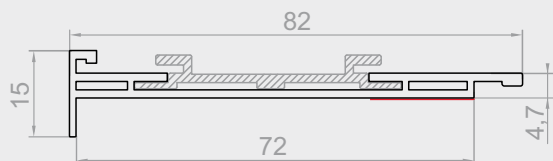
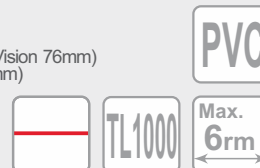

RN 1-70

Universal adaptation profile
For window profiles:

Kömmerling (EuroFutur Classic 70mm, Elegance 70mm, MD Classic 70mm, MD Classic półzłocowany 70mm)
KBE (System z uszczelką przylegową 58mm, 70mm)
Rehau (Geneo 86mm), Oknoplast Kraków (70mm)
Schüco (Corona CT 70 70mm)
Salamander (Salamander 3D 76mm, SL 76mm, Vision 76mm)
Deceuninck (Zendów 3k 70mm, projekt 3000 70mm)
Deceuninck - Thyssen (Prestige 76mm, Prestige Passiv-Haus 76mm)
Wymar (Wymar 60 60mm, Wymar 72 70mm)
Decco (7010 70mm)
Brüggmann (AD 73mm, MD 73mm)

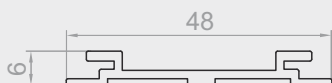

NPL-020

Adapter aluminium insert RN 1-70.

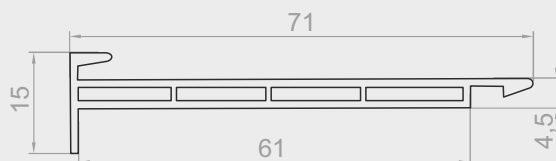

RN1

Adaptation profile
For window profiles:

Kömmerling (EuroFutur Classic 70mm, Elegance 70mm, MD Classic 70mm, MD Classic półzłocowany 70mm)
KBE (System z uszczelką przylegową 58mm, 70mm)
Rehau (Geneo 86mm)
Oknoplast Kraków (70mm)
Schüco (Corona SI 82, 82+: 82 mm)
Salamander (Salamander 3D 76mm, SL 76mm, Vision 76mm)
Deceuninck (Zendów 3k 70mm, projekt 3000 70mm)
Deceuninck - Thyssen (Prestige 76mm, Prestige Passiv-Haus 76mm)
Wymar (Wymar 60 60mm, Wymar 72 70mm)
Decco (7010 70mm)
Aluplast (Ideal 7000 80mm)

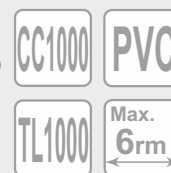

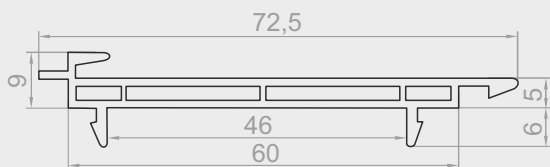

RN5

Adaptation profile
 For window profiles:

Veka (Softline 58mm, 70mm)
 Kömmerling (58mm)
 Deceuninck (Zendów 5k 70mm, Zendów 70 70mm)
 Deceuninck-Thyssen (Optima 71mm)

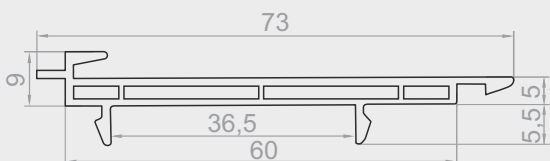

RN10

Adaptation profile
 For window profiles:

Aluplast (Ideal 2000 60mm, 4000 70mm, 5000 70mm)
 Drutex (Igló 5 70mm)



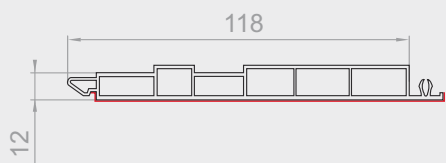

PKL1

Inspection cover of the box 160, 200.

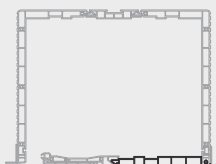

BOX
160,200

Max.
6mm

TL1000

PVC

1mm
0,55kg

Pb

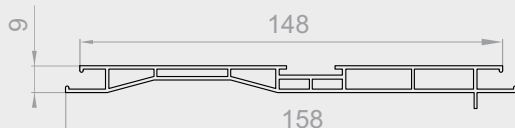

PGL 1-K

Top profile of the box 160.



TL1000

BOX
160

Max.
6mm

PVC

1mm
0,64kg

Pb

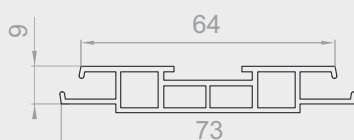

PGL 2-K

Top profile of the box 200.



TL1000

BOX
200

Max.
6mm

PVC

1mm
0,38kg

Pb

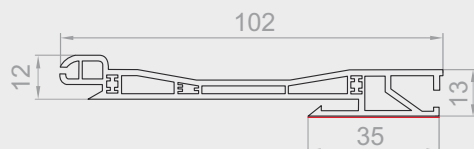

RK2

Mounting profile of the box 135, 160, 200.



BOX
135,160,200

Max.
6mm

CC1000

PVC

1mm
0,48kg

Pb

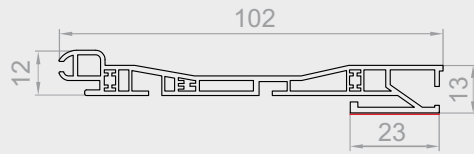

RK2 70

Mounting profile of the box 160, 200.

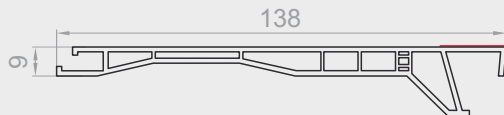
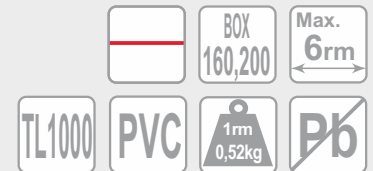
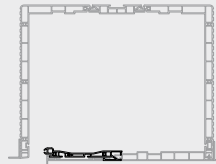

RK 3

Top profile of the box 135, 160, 200.

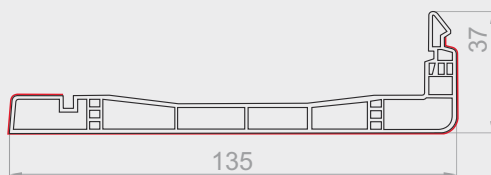
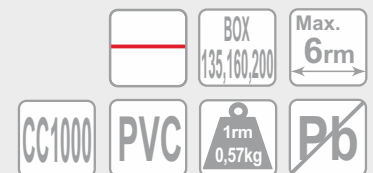
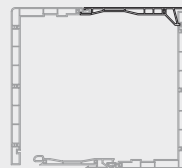

RK 40

Inner and outer cover of the box 135.

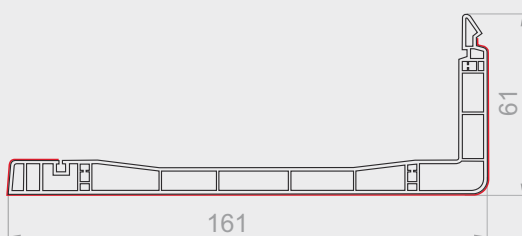
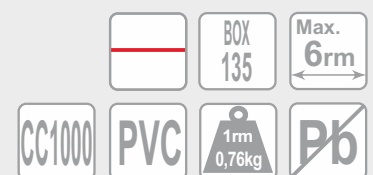
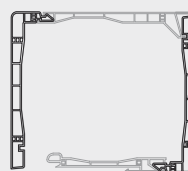

RK 50

Outer cover of the box 160 - TL1000.
Inner and outer cover of the box 160 - CC1000.

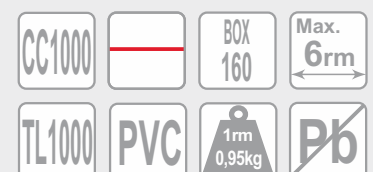
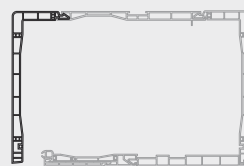

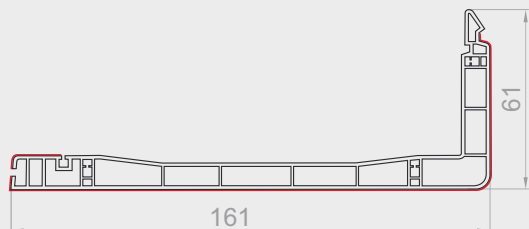

RKT 50

Inner cover of the box 160.

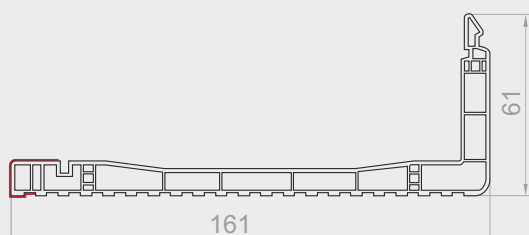
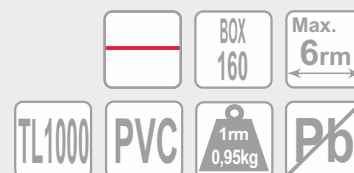
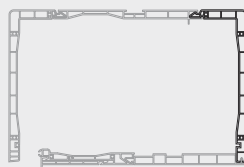

RK50 R

Outer cover of the box 160 - grooved - TL1000.
Outer cover of the box 160 - grooved - CC1000.

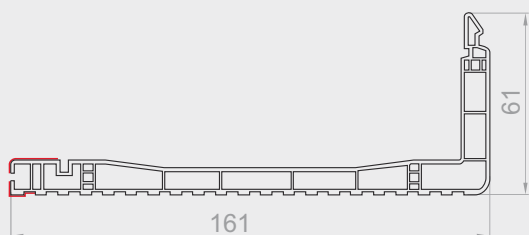
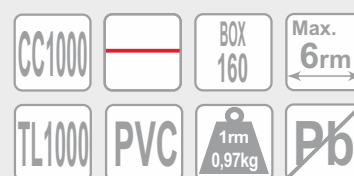
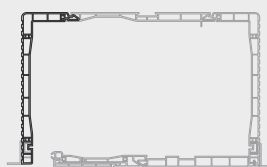

RKTR 50

Inner cover of the box 160 - grooved.

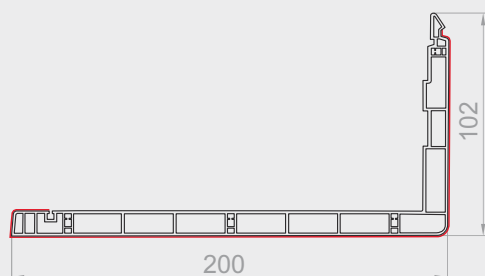
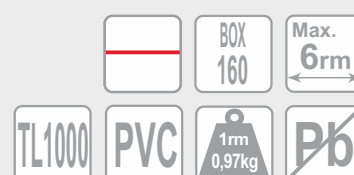

RK 60

Outer cover of the box 200 - TL1000.
Inner and outer cover of the box 200 - CC1000.

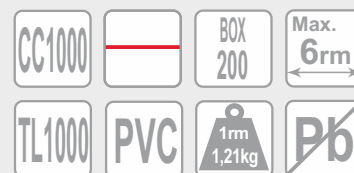

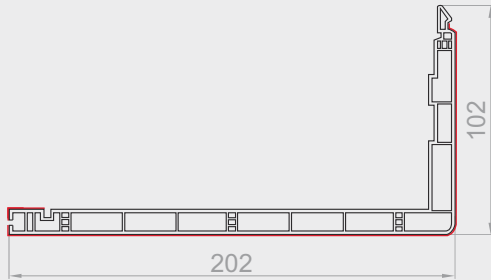

RKT 60

Inner cover of the box 200.

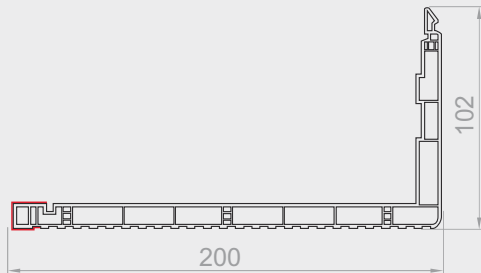
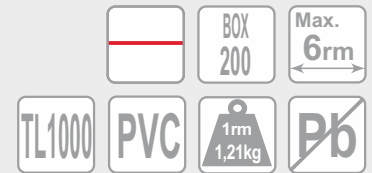
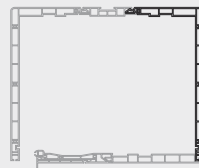

RK60 R

Outer cover of the box 200 - grooved - TL1000.
 Outer cover of the box 200 - grooved - CC1000.

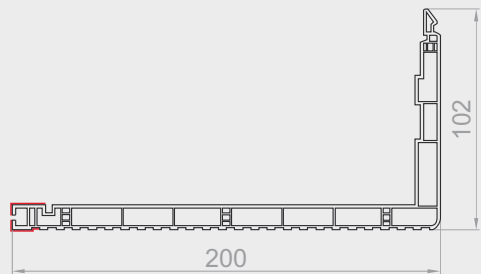
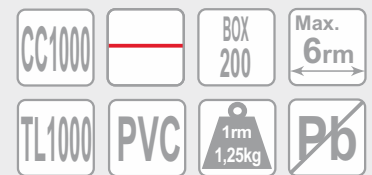
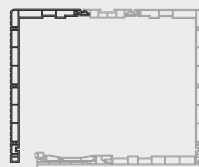

RKTR 60

Inner cover of the box 200 - grooved.

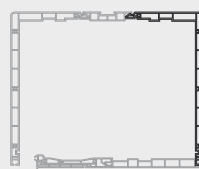

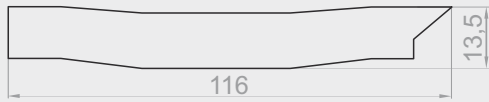

RW 1

Thermal insulation of the box 135 mm.

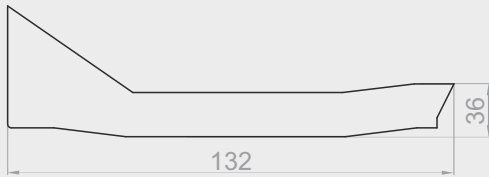
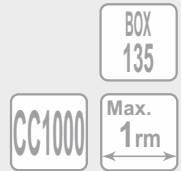
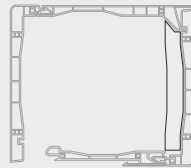

RW 2

Thermal insulation of the box 160 mm.

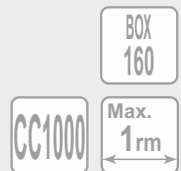
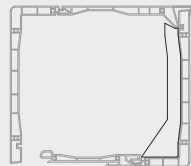

RW 3

Thermal insulation of the box 200 mm.

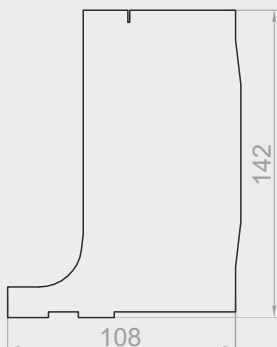
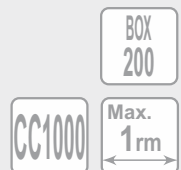
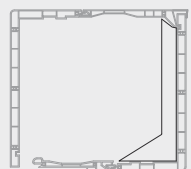

BPRN 200

Styrofoam insert of the box 160.

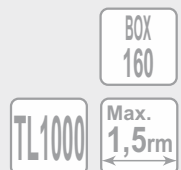
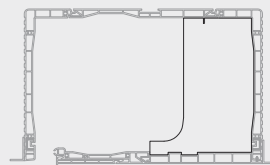

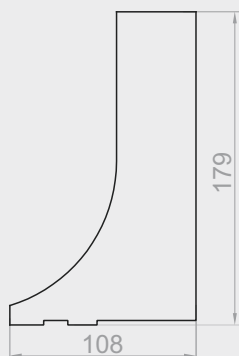

BPRN 300

Styrofoam insert of the box 200.

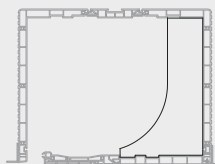

BOX
200

TL1000

Max.
1,5m



BPRN 300 2/S

Bottom styrofoam insert of the box 200.

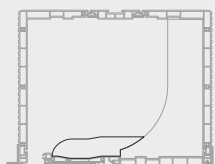

BOX
200

TL1000

Max.
1,5m

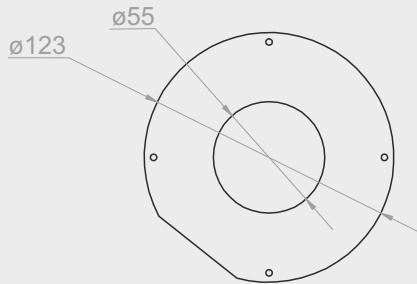

OWCT 135/40

Inner cover of the box 135 mm for pipe $\varnothing 40$.

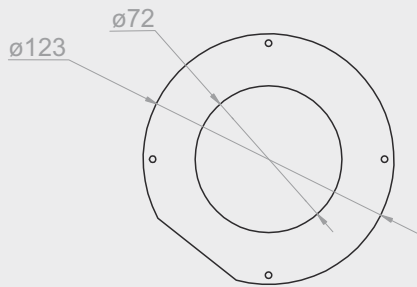
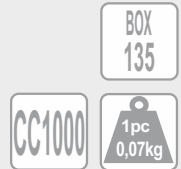
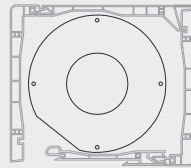

OWCT 135/60

Inner cover of the box 135 mm for pipe $\varnothing 60$.

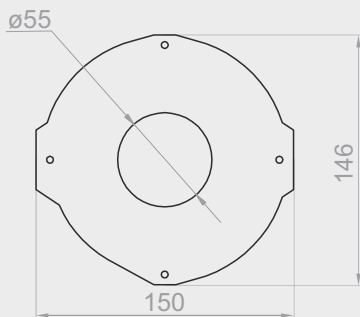
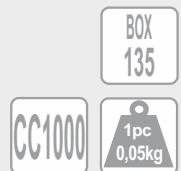
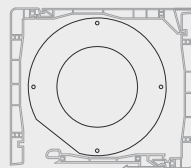

OWCT 160/40

Inner cover of the box 160 mm for pipe $\varnothing 40$.

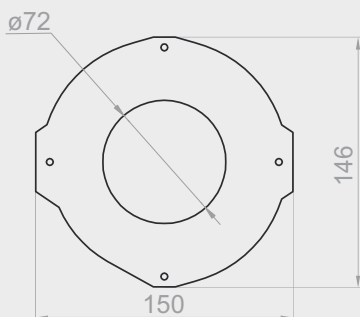
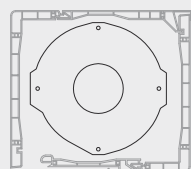

OWCT 160/60

Inner cover of the box 160 mm for pipe $\varnothing 60$.

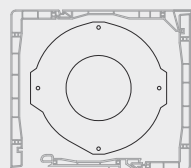

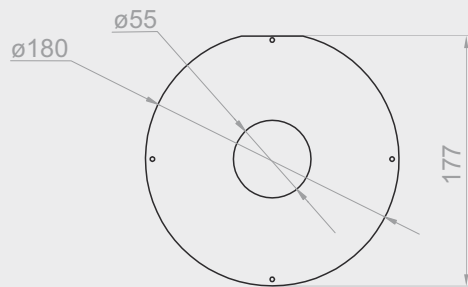

OWCT 200/40

Inner cover of the box 200 mm for pipe \varnothing 40.

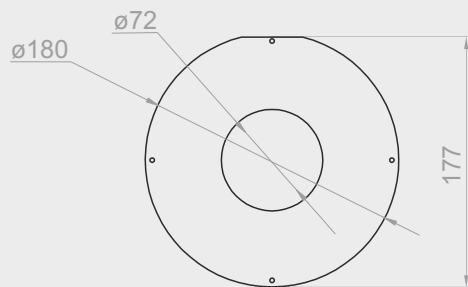
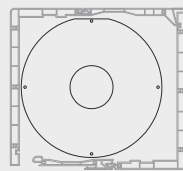

OWCT 200/60

Inner cover of the box 200 mm for pipe \varnothing 60.

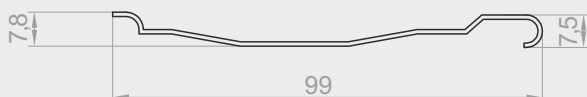
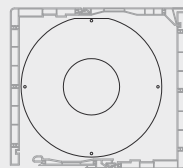

RA-10 99mm

Steel box reinforcement 135, 160, 200 - large.

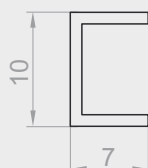
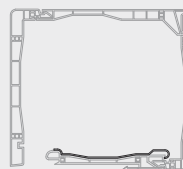

RA-2-00 7 MM

Steel box reinforcement 160, 200 - small
 (for the concealed lath).

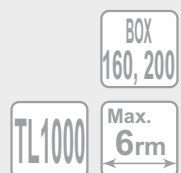

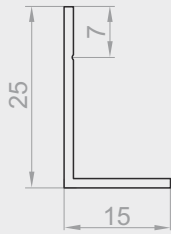

LT

Concealed lath of the box 160, 200.

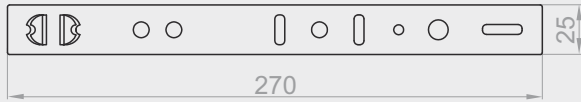
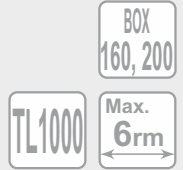

SKM-TL1000

Steel mounting anchor.

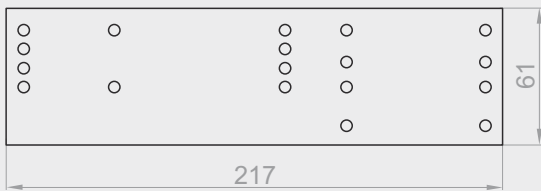
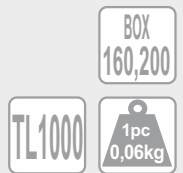

RKZ 66

Steel side handle for box.

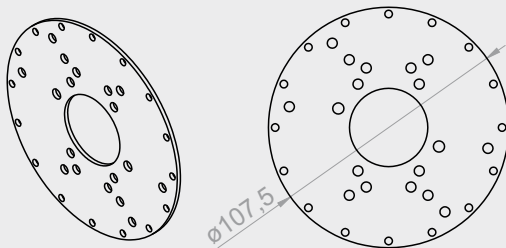

RKZ 56

Plate for installation of motors.

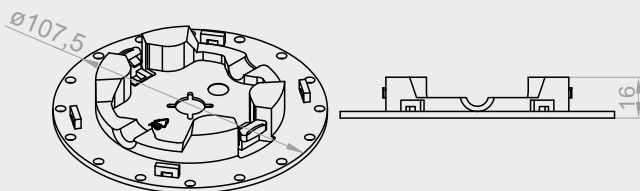

US-PADS 60

Plate for installation of motors for $\varnothing 60$ pipe.



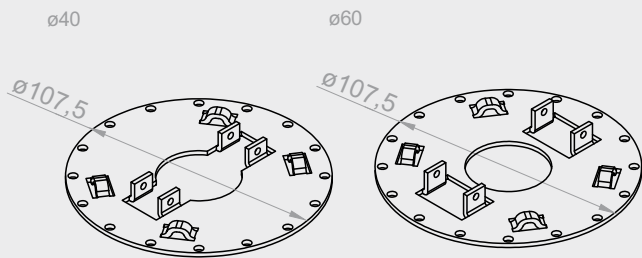

RKZ P4

Plate for installation of motors for ø40 pipe.

RKZ P6

Plate for installation of motors for ø60 pipe.

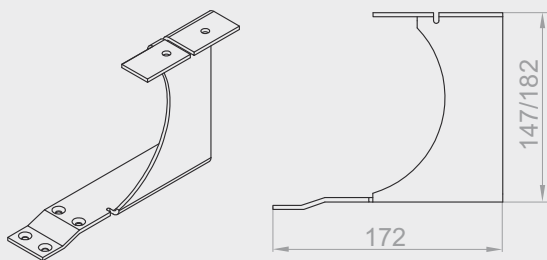

KNS-160

Stabilizing console for box 160 without reinforcement.

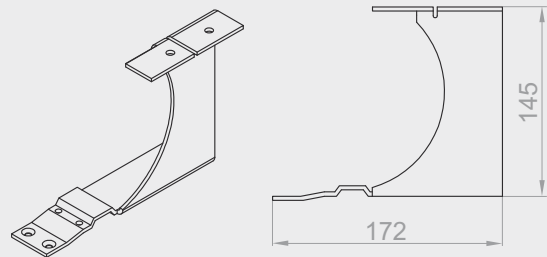
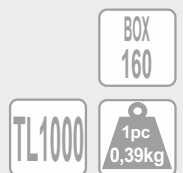
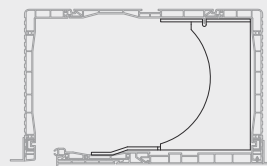

KNS-WSP-160

Stabilizing console for box 160 with reinforcement.

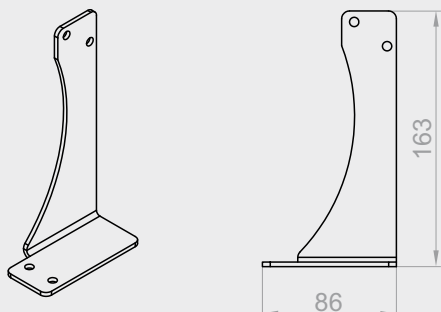
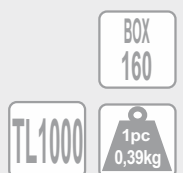

KNST-200

Component of the stabilizing console for box 200 with / without reinforcement.



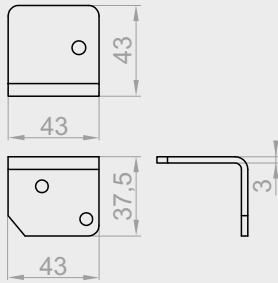
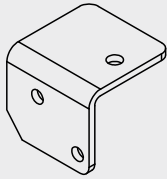

KNST-030

Upper connector of the stabilizing console for box 200 with / without reinforcement.

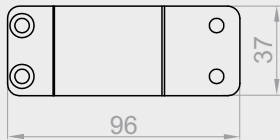
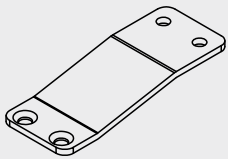

KNST-040

Lower connector of the stabilizing console for box 200 without reinforcement.

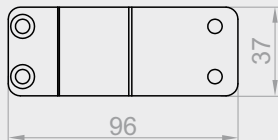
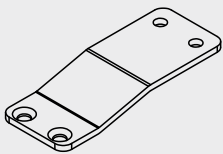

KNST-050

Lower connector of the stabilizing console for box 200 with reinforcement.



View of the stabilizing console with connectors.

KNSK-WSP-200
(with reinforcement)

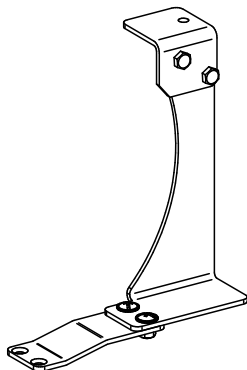

KNSK-200
(without reinforcement)

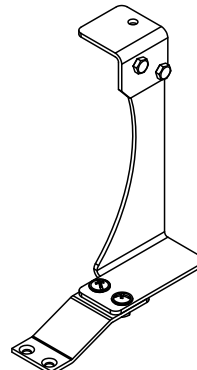

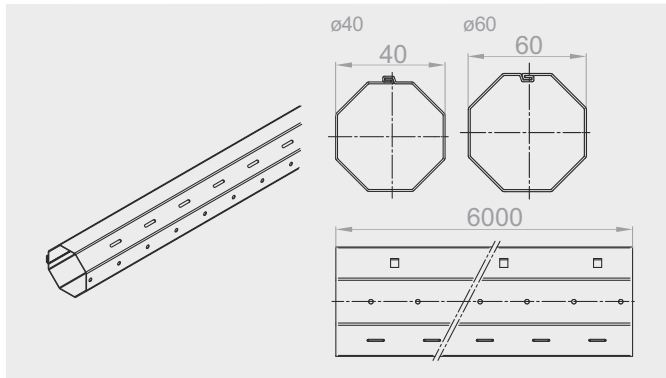

SW 40

Octagonal pipe ø 40.

SW 60

Octagonal pipe ø 60.

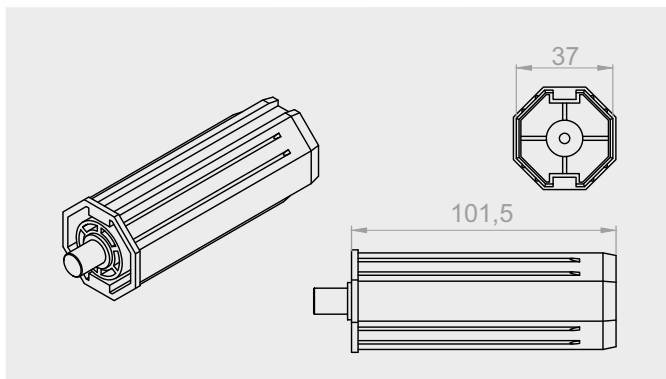
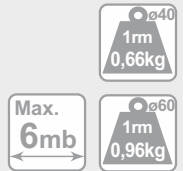
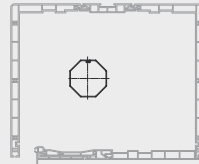

OBS-40-PVC

PVC mounting with pin for pipe ø 40.

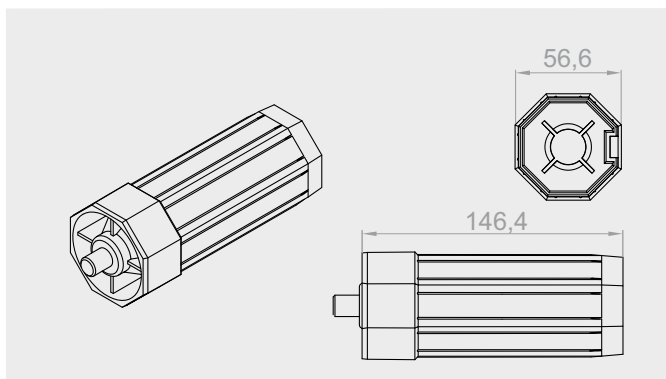

OBS-60-PVC

PVC mounting with pin for pipe ø 60.

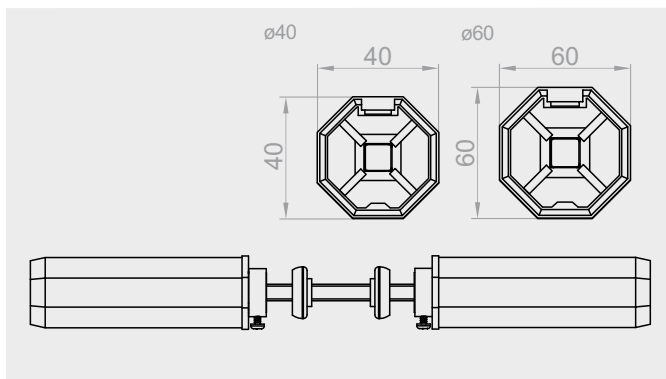

RKZ 34

Roller bolt for ø 40 pipe
(to transfer power).

RKZ 35

Roller bolt for ø 60 pipe
(to transfer power).



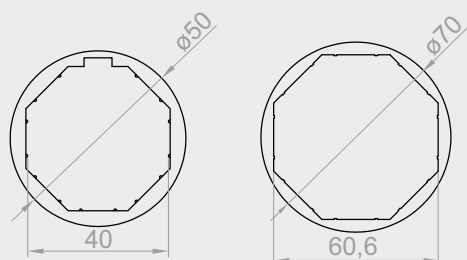

PZ 40/50

Expansion ring 40/50.

PZ 60/70

Expansion ring 60/70.

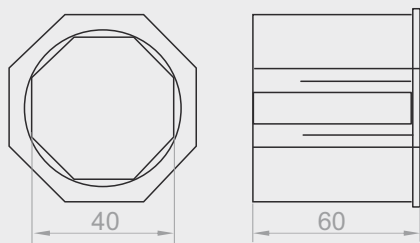

RED-40-60

Reduction 40/60.

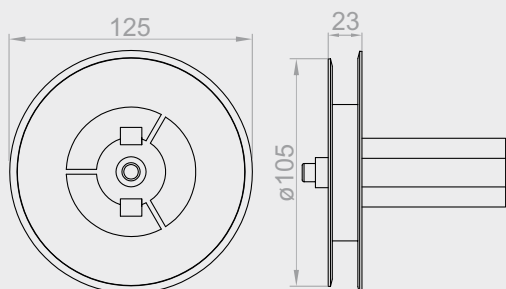

RKZ 70

Winding wheel for box 135.

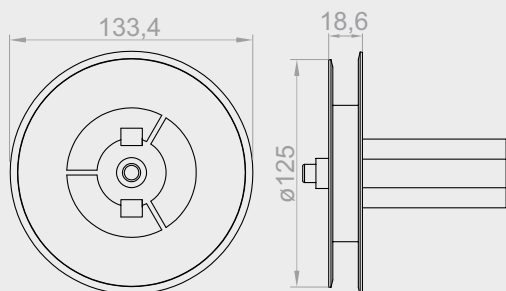

RKZ 71

Winding wheel for box 160.



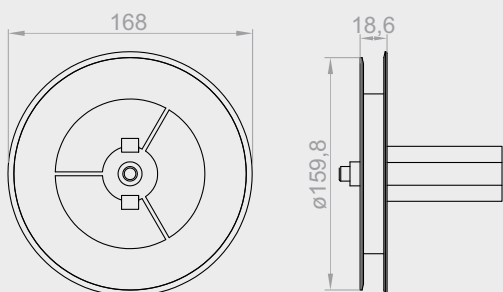

RKZ 72

Winding wheel for box 200.

BOX
200

ABS

1 pc
0,14kg

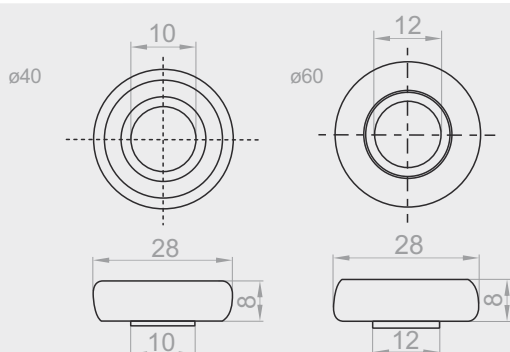

LO-28/10

Bearing for PVC boxes for \varnothing 40.

LO-28/12 PCV

Bearing for PVC boxes for \varnothing 60.

1 pc
0,02kg

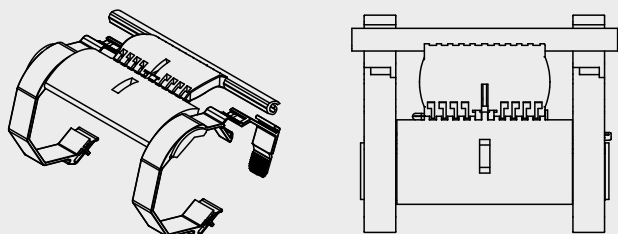

WB1-40 W

2-piece blocking hitch bracket for \varnothing 40 pipe.

WB1-60 W

2-piece blocking hitch bracket for \varnothing 60 pipe.

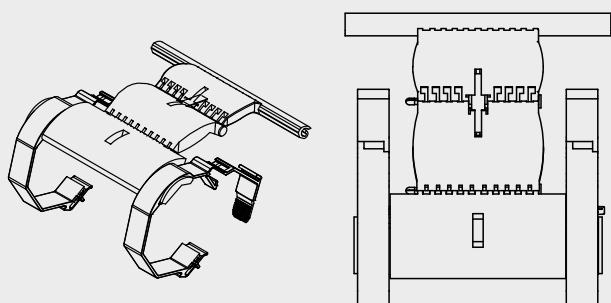

WB3-40 W

3-piece blocking hitch bracket for \varnothing 40 pipe.

WB3-60 W

3-piece blocking hitch bracket for \varnothing 60 pipe.

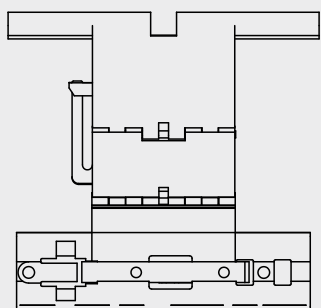

WBZ1-40

1-piece blocking hitch bracket for \varnothing 40 pipe.

WBZ2-40

2-piece blocking hitch bracket for \varnothing 40 pipe.

WBZ1-60

1-piece blocking hitch bracket for \varnothing 60 pipe.

WBZ2-60

2-piece blocking hitch bracket for \varnothing 60 pipe.

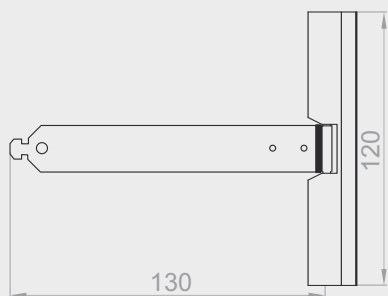

WS-37/40-130

Steel hanger 130.



WS-37/40-170

Steel hanger 170.

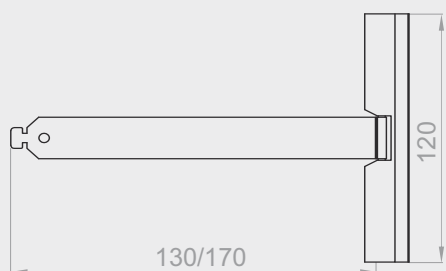

WS-37/40-130 S

Steel hanger 130 (electrically powered shutters).

WS-37/40-170 S

Steel hanger 170 (electrically powered shutters).



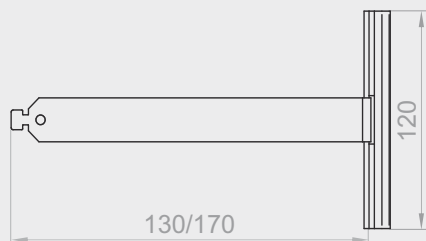

WS-37/40-130 ALU

Aluminium hanger.

WS-37/40-170 ALU

Aluminium hanger.

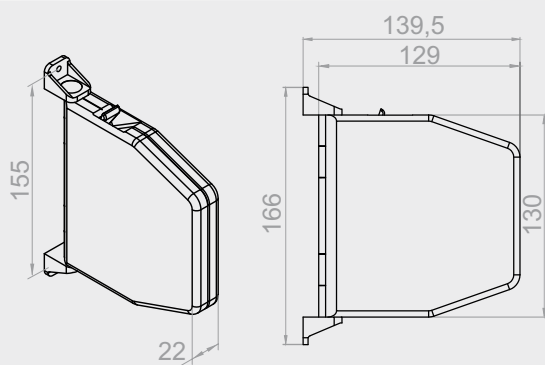

ZT-5M XX

Tape coiler 5m white

Available in colors (XX):

02 - white, 08 - dark brown.

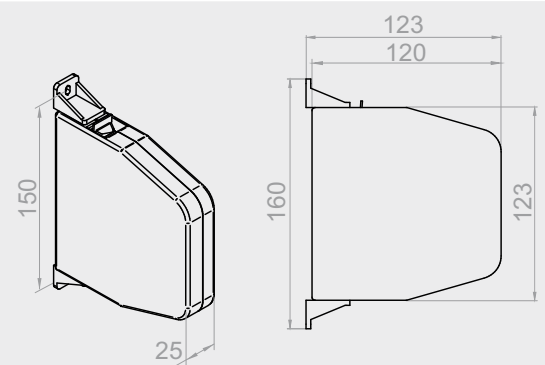

ZT/L-5M-XX

Universal tape / cord coiler up to 5m

Available in colors (XX):

23 - anthracite.

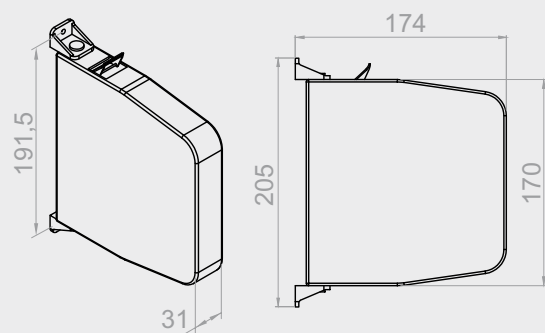

ZT-11M XX

Tape coiler 11m.

Available in colors (XX):

02 - white, 08 - dark brown.



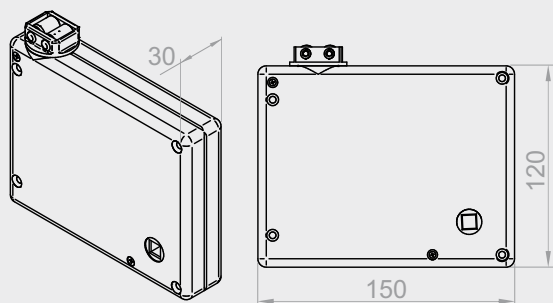

KPTKM-XX

Cassette with tape transmission.
Available in colors (XX):
02 - white, 08 - dark brown.

KPLKM-XX

Cassette with cord transmission.
Available in colors (XX):
02 - white, 08 - dark brown.

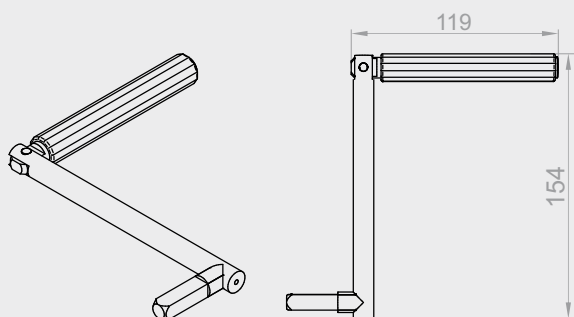

KRM-140

Mignon crank 140 mm.

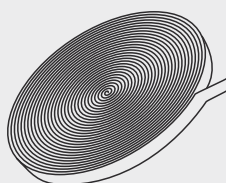

TS-14-XX

Tape.
Available in colors (XX):
03 - gray, 08 - dark brown, 23 - anthracite.

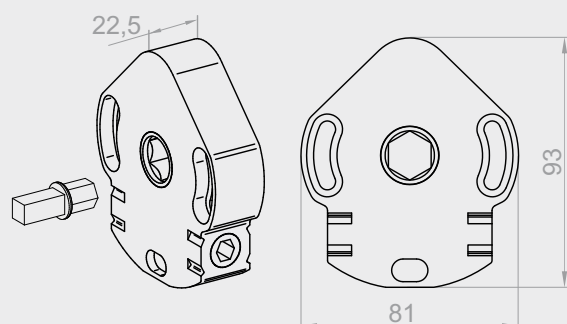

ACE-1-8 MAŁY

Crank mechanism - 22 kg.



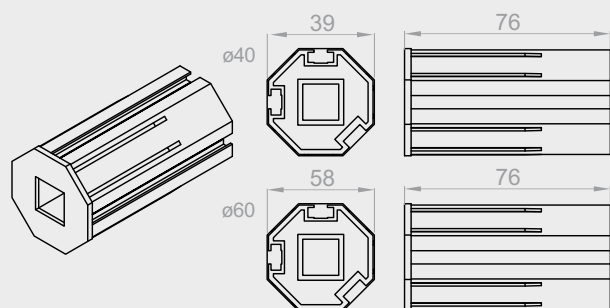

OBS-40-ACE

ø40 mounting for the ACE mechanism.

OBS-60-ACE

ø60 mounting for the ACE mechanism.

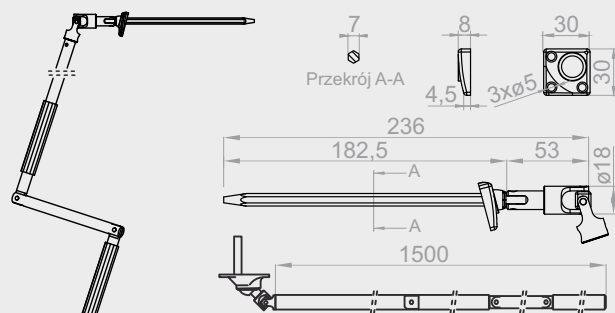

KRH-ZF

Cardan 165 with 1430 mm crank.

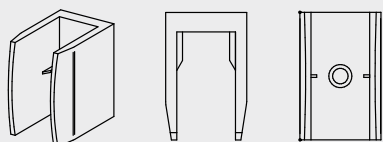

U-KRD

Handle for mounting the crank.

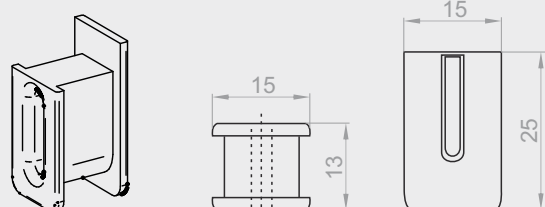

E-R265-6

Belt guide - 02 (white).

E-R265-7

Belt guide - 08 (brown).

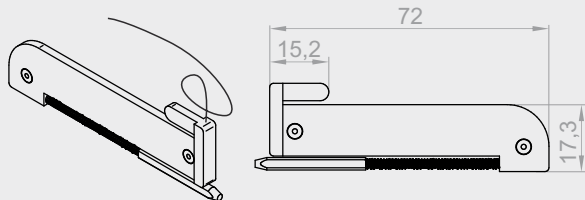

RA

Automatic bolt.
Minimum shutter width - 45 cm.
Minimum shutter height - 90 cm.

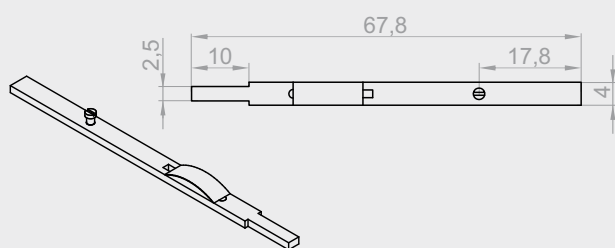

ZR

Latch (manual bolt)
Minimum shutter width - 45 cm.

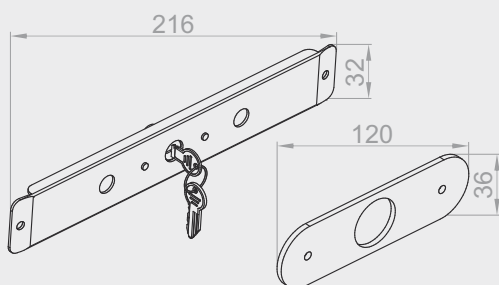

ZB

Cylinder lock, set of keys (3 pieces) and covering plate.
The covering plate is mounted as standard from the outside.

Minimum shutter width - 45 cm.

Available in colors (XX):

01 - silver, 02 - white, 03 - gray, 04 - dark beige, 05 - light beige, 07 - light gray, 08 - dark brown, 09 - light brown, 13 - green, 15 - cream white, 16 - ivory, 19 - maroon, 20 - black, 23 - anthracite, 26 - steel olive.

NYP

NYP45

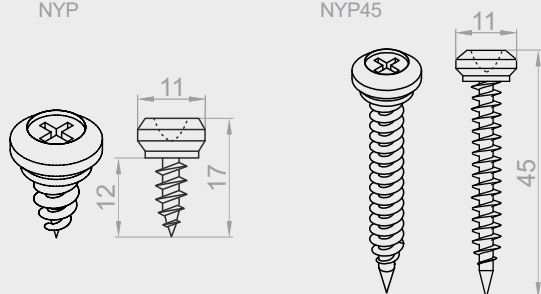

NYP

Guide nipple.

NYP45

45 mm guide nipple.

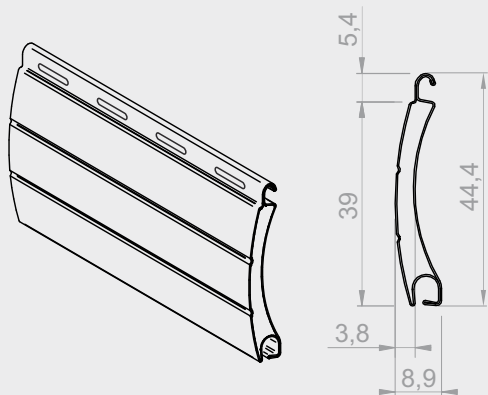

PA 39/0k

PA 39 Aluminium profile - perforated.

PA 39/1k

PA 39 Aluminum profile - non-perforated.

Profile height	39 mm
Profile thickness	8,9 mm
Profile weight 1 m ²	2,8 kg
Maximum profile length	6 rm
Number of laths 1m high	26 pcs
Maximum area	6,5 m ²
Maximum shutter width	2500 mm

Profile colors (k)	
01 - silver	[Color swatch]
02 - white	[Color swatch]
03 - grey	[Color swatch]
04 - dark beige	[Color swatch]
05 - beige	[Color swatch]
07 - light grey	[Color swatch]
08 - dark brown	[Color swatch]
09 - brown	[Color swatch]
13 - green	[Color swatch]
15 - cream white	[Color swatch]
16 - ivory	[Color swatch]
19 - maroon	[Color swatch]
20 - black	[Color swatch]
22 - mahogany	[Color swatch]
23 - anthracite	[Color swatch]
24 - steel anthracite DB703	[Color swatch]
26 - steel olive	[Color swatch]
27 - basalt grey	[Color swatch]
30 - walnut	[Color swatch]
34 - bog oak	[Color swatch]
48 - golden oak	[Color swatch]
54 - winchester	[Color swatch]

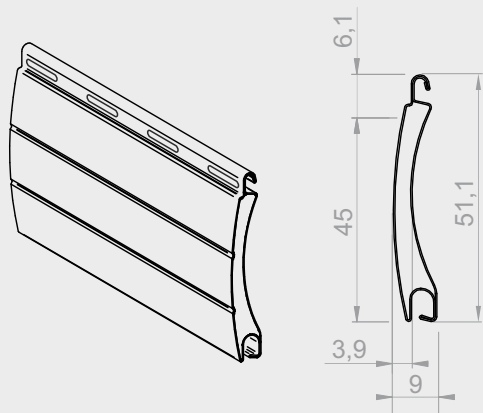

PA 45/0k

PA 45 Aluminium profile - perforated.

PA 45/1k

PA 45 Aluminum profile - non-perforated.

Profile height	45 mm
Profile thickness	9 mm
Profile weight 1 m ²	2,9 kg
Maximum profile length	5,4 rm
Number of laths 1m high	23 pcs
Maximum area	6,5 m ²
Maximum shutter width	3000 mm

Profile colors (k)	
01 - silver	[Color swatch]
02 - white	[Color swatch]
03 - grey	[Color swatch]
04 - dark beige	[Color swatch]
05 - beige	[Color swatch]
07 - light grey	[Color swatch]
08 - dark brown	[Color swatch]
09 - brown	[Color swatch]
13 - green	[Color swatch]
15 - cream white	[Color swatch]
16 - ivory	[Color swatch]
19 - maroon	[Color swatch]
20 - black	[Color swatch]
22 - mahogany	[Color swatch]
23 - anthracite	[Color swatch]
26 - steel olive	[Color swatch]
30 - walnut	[Color swatch]
48 - Golden oak	[Color swatch]
54 - winchester	[Color swatch]

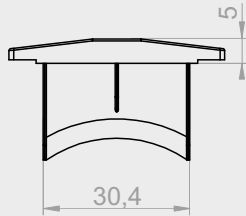
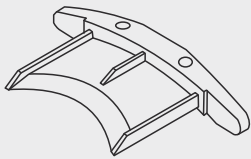

APA 39 M

PA 39 Profile plug.

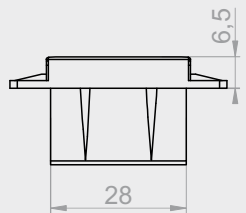
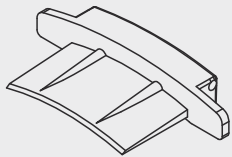

APA 37-R

PA 39 Profile plug bolt.

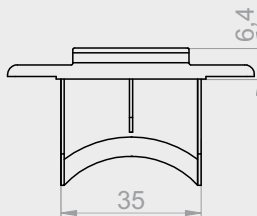
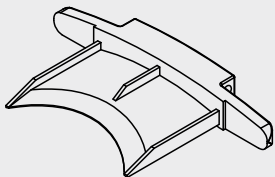

APA 45-R

PA 45 Profile plug bolt.

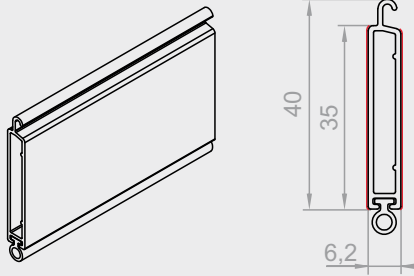

LD-35 MINI

Bottom lath for profiles PA 39, PA 45, PVC 37 with KA-44B seal.

Index/color (XX)	01 - silver	02 - white	03 - gray	04 - dark beige	05 - light beige	07 - light gray	08 - dark brown	09 - light brown	13 - green	15 - cream white	16 - ivory	19 - maroon	20 - black	22 - mahogany	23 - anthracite	26 - steel olive	27 - basalt gray	30 - walnut	34 - Bog oak	48 - golden oak	54 - winchester	
LD-35 MINI XX	X	X	X	X	X	X	X	X	X	X	X	X	X	X	X	X	X	X	X	X	X	X

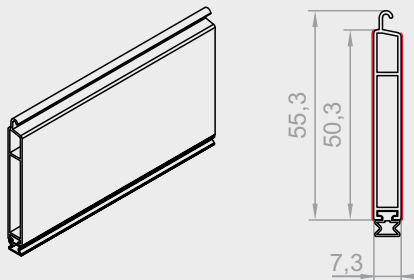

LD-37

Bottom lath for profiles PA 39, PA 45, PVC 37 with KA-44 seal.

Index/color (XX)	01 - silver	02 - white	03 - gray	04 - dark beige	05 - light beige	07 - light gray	08 - dark brown	09 - light brown	13 - green	15 - cream white	16 - ivory	19 - maroon	20 - black	22 - mahogany	23 - anthracite	26 - steel olive	27 - basalt gray	30 - walnut	34 - Bog oak	48 - golden oak	54 - winchester	
LD-37 XX	X	X	X	X	X	X	X	X	X	X	X	X	X	X	X	X	X	X	X	X	X	X

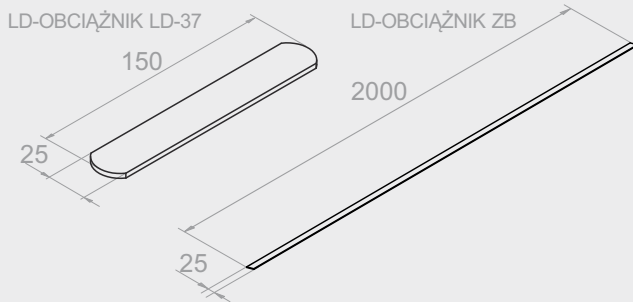

LD-OBCIAŻNIK LD-37

Bottom lath weight 15 cm.

LD-OBCIAŻNIK ZB

200 cm bottom lath weight - for cylinder lock.

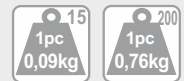

BF

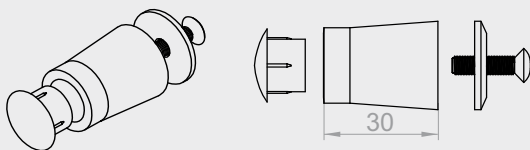

BF (without the profile plug)

BF-ZAT

Bottom lath buffer

} SET

Index/color (XX)	01 - silver	02 - white	03 - gray	04 - dark beige	05 - light beige	07 - light gray	08 - dark brown	09 - light brown	13 - green	15 - cream white	16 - ivory	19 - maroon	20 - black	22 - mahogany	23 - anthracite	26 - steel olive	27 - basalt gray	30 - walnut	34 - Bog oak	48 - golden oak	54 - winchester	
BF XX/BF-ZAT XX	X	X	X	X	X	X	X	X	X	X	X	X	X	X	X	X	X	X	X	X	X	X

BF-40 MM

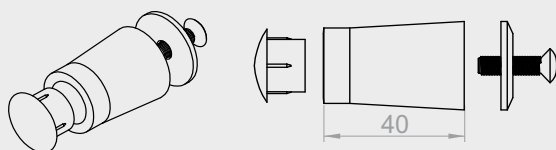

BF-40 MM (without the profile plug)

BF-ZAT

Bottom lath buffer

} SET

Index/color (XX)	01 - silver	02 - white	03 - gray	04 - dark beige	05 - light beige	07 - light gray	08 - dark brown	09 - light brown	13 - green	15 - cream white	16 - ivory	19 - maroon	20 - black	22 - mahogany	23 - anthracite	26 - steel olive	27 - basalt gray	30 - walnut	34 - Bog oak	48 - golden oak	54 - winchester	
BF-40 XX/BF-ZAT XX	X	X	X	X	X	X	X	X	X	X	X	X	X	X	X	X	X	X	X	X	X	X



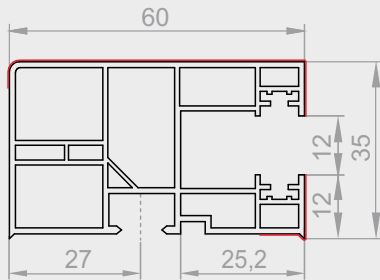

RK-16

Single guide with brush seal.

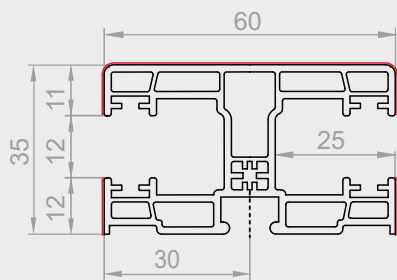
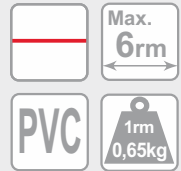

RK-18

Single / double guide with brush seal.

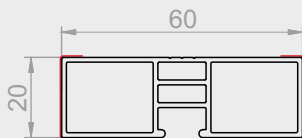

DP-PCV-20

60x20 guide spacer.

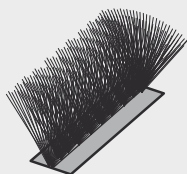
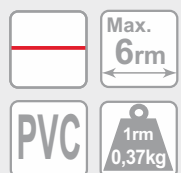

SP-7x6-3P SP

Brush seal for guides.

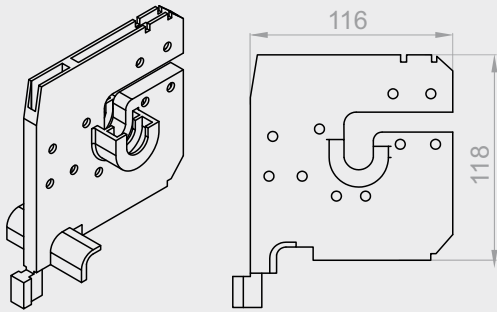

RKM101

135 box division for a double guide.

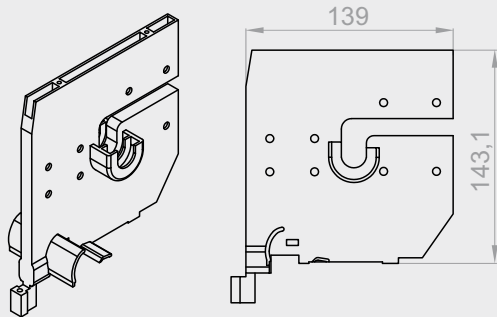
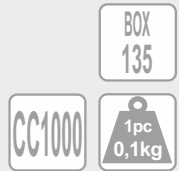
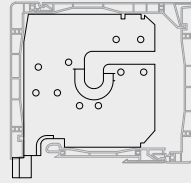

RKM201

160 box division for a double guide.

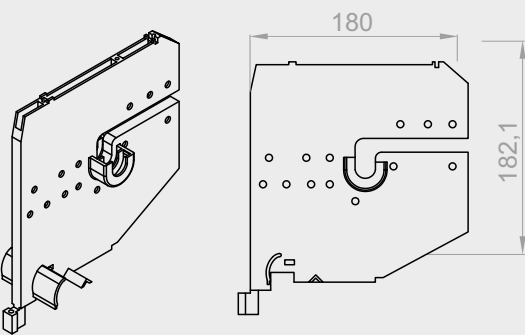
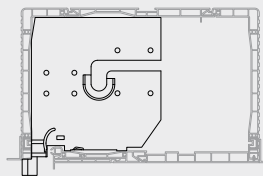

RKM301

200 box division for a double guide.

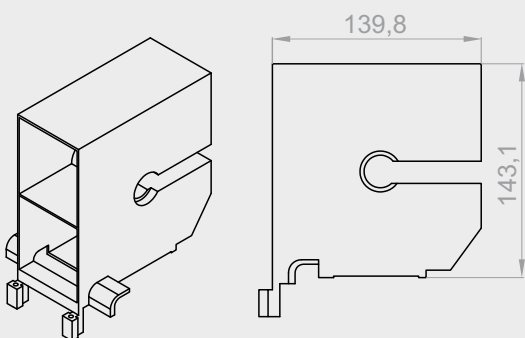
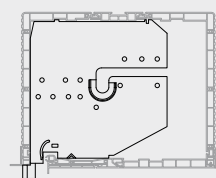

RKB2

160 box division for two single guides.

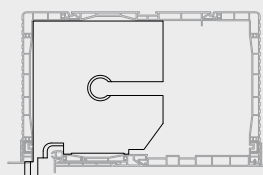

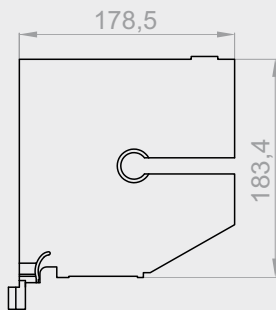
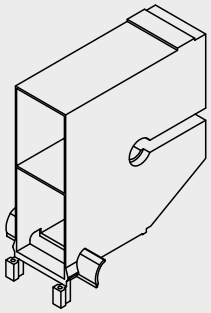

RKB3

200 box division for two single guides.

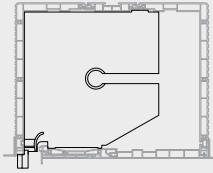

BOX
200

1pc
0,2kg

*ASSEMBLY
DRAWINGS*

Division for a double guide in a shutter with independent drive.

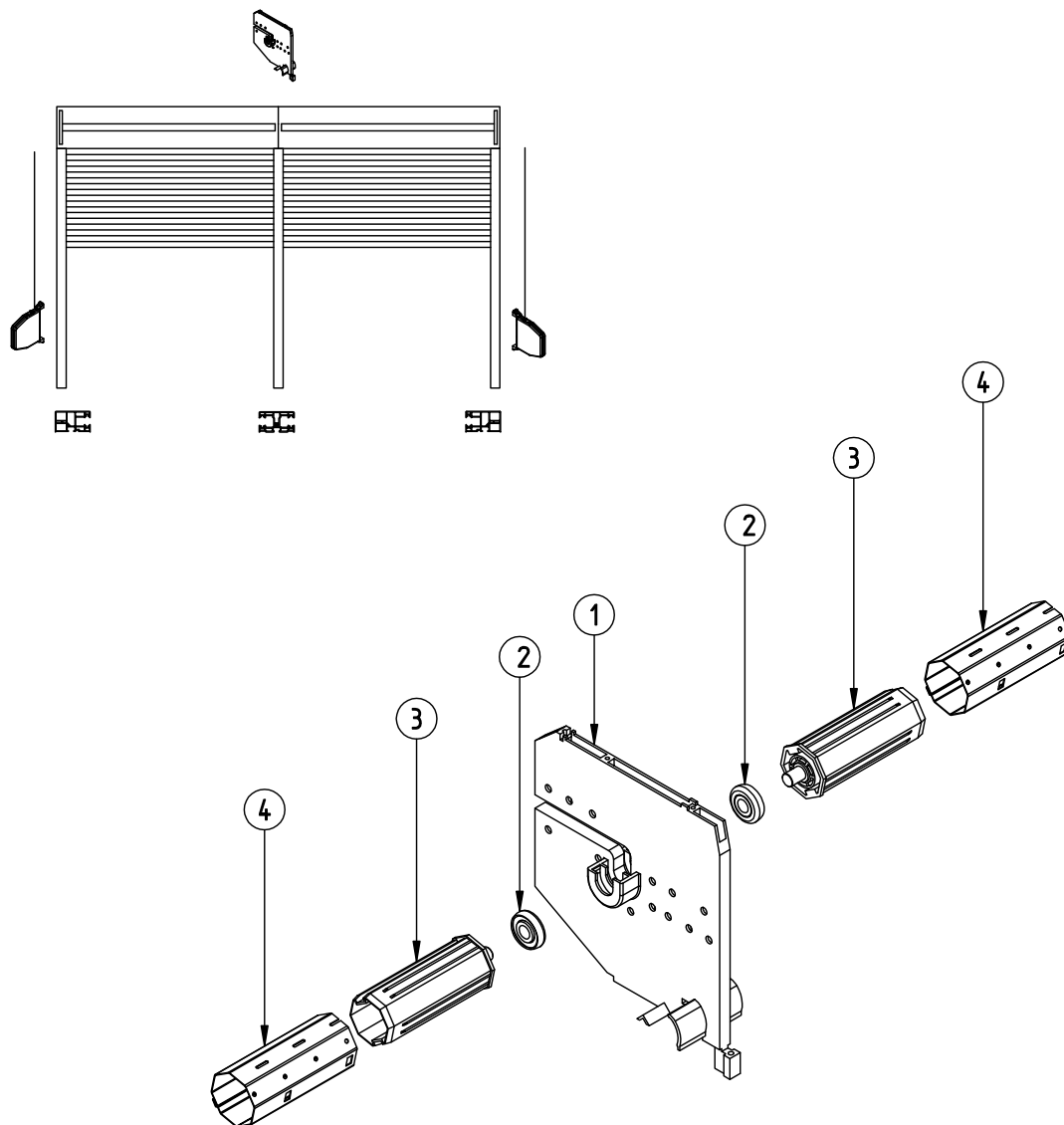

1	RKM101	135 box division for a double guide
	RKM201	160 box division for a double guide
	RKM301	200 box division for a double guide
2	LO 28/10	Bearing 28/10 for PVC
	LO 28/12 PCV	Bearing 28/12 for PVC
3	OBS-40-PCV	40 mounting for \varnothing 40 pipe with pin
	OBS-60-PCV	60 mounting for \varnothing 60 pipe with pin
4	SW 40	Octagonal pipe \varnothing 40
	SW 60	Octagonal pipe \varnothing 60

Division for a double guide in a shutter with dependent drive.

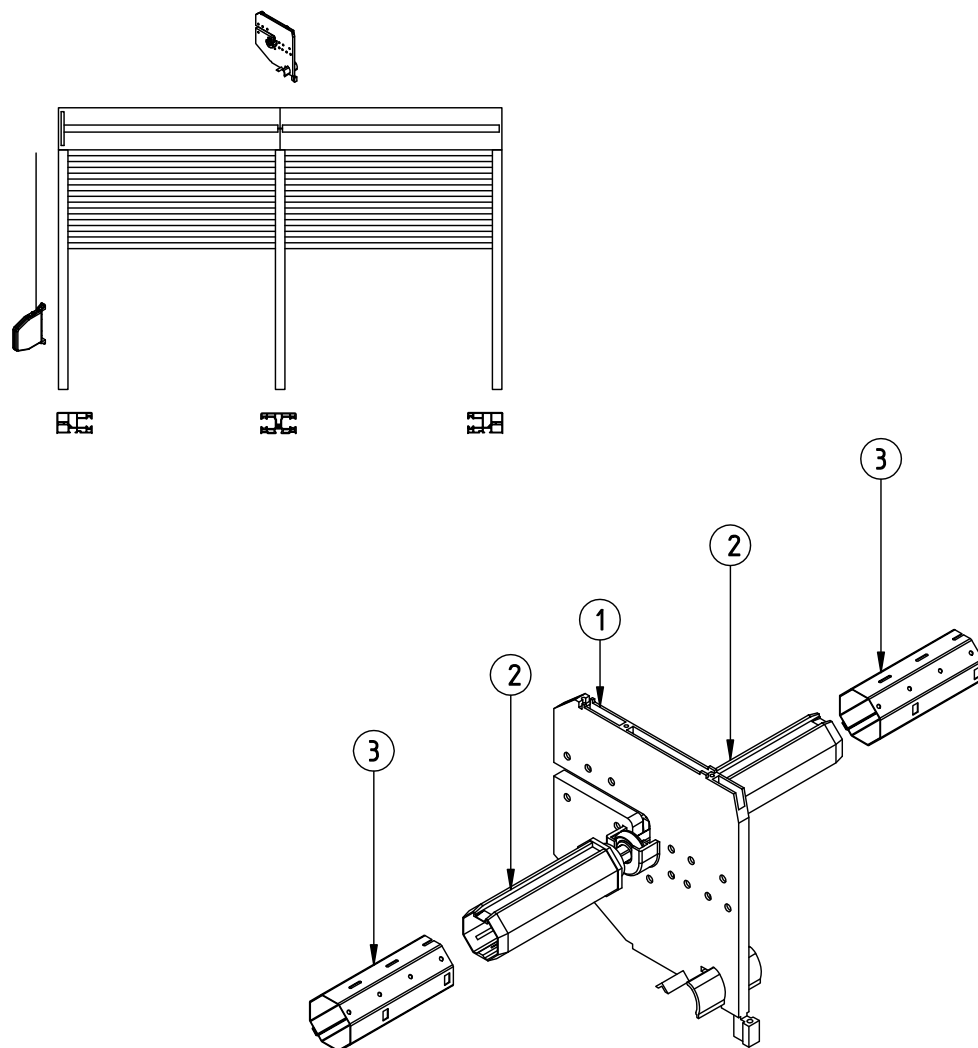

1	RKM101	135 box division for a double guide
	RKM201	160 box division for a double guide
	RKM301	200 box division for a double guide
2	RKZ34	Roller bolt for \varnothing 40 pipe
	RKZ35	Roller bolt for \varnothing 60 pipe
3	SW 40	Octagonal pipe \varnothing 40
	SW 60	Octagonal pipe \varnothing 60

Division for two single guides in a shutter with independent drive.

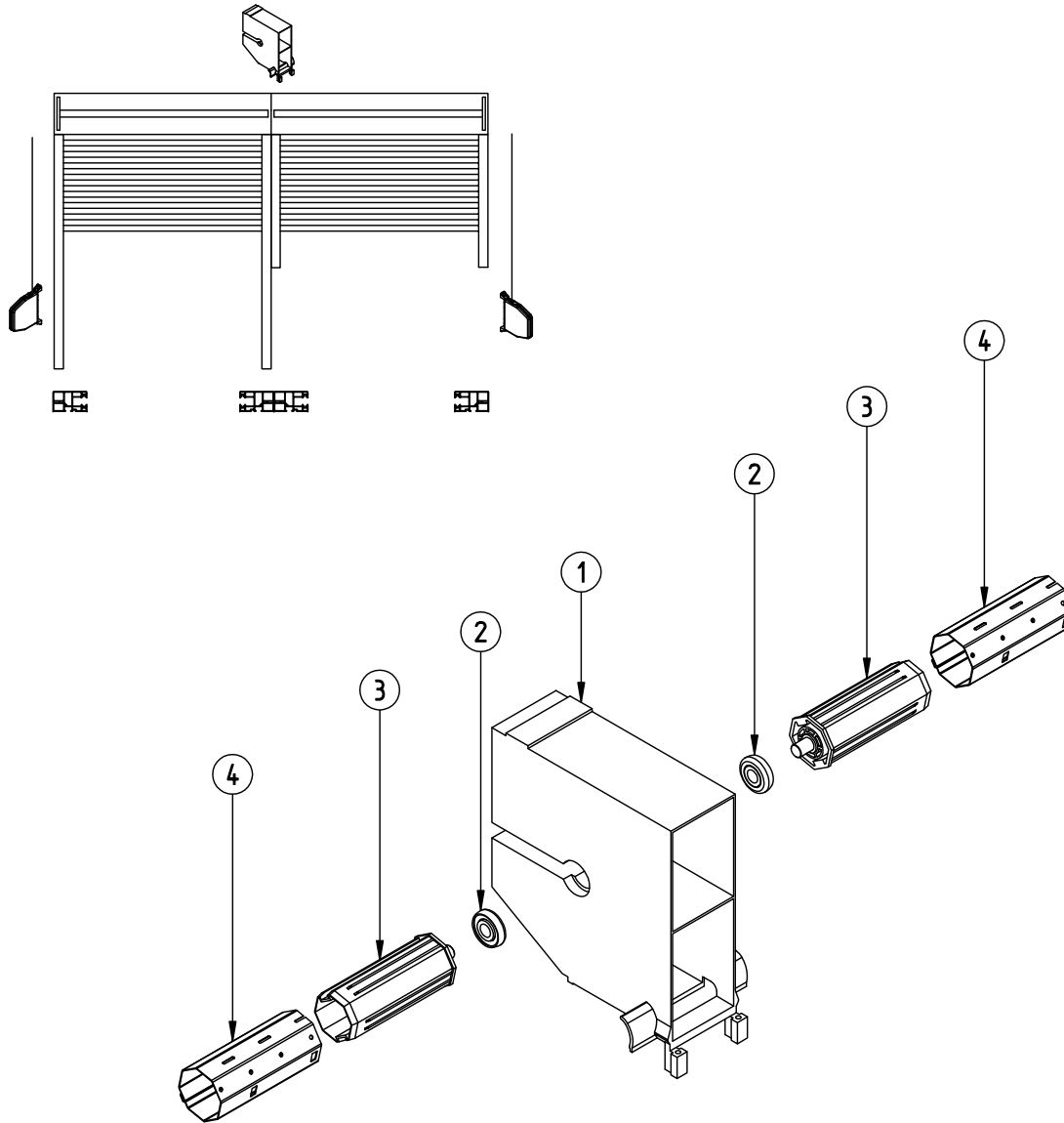

1	RKB2	160 box division for two single guides
	RKB3	200 box division for two single guides
2	LO 28/10	Bearing 28/10 for PVC
	LO 28/12 PCV	Bearing 28/12 for PVC
3	OBS-40-PCV	40 mounting for \varnothing 40 pipe with pin
	OBS-60-PCV	60 mounting for \varnothing 60 pipe with pin
4	SW 40	Octagonal pipe \varnothing 40
	SW 60	Octagonal pipe \varnothing 60

Division for two single guides in a shutter with dependent drive.

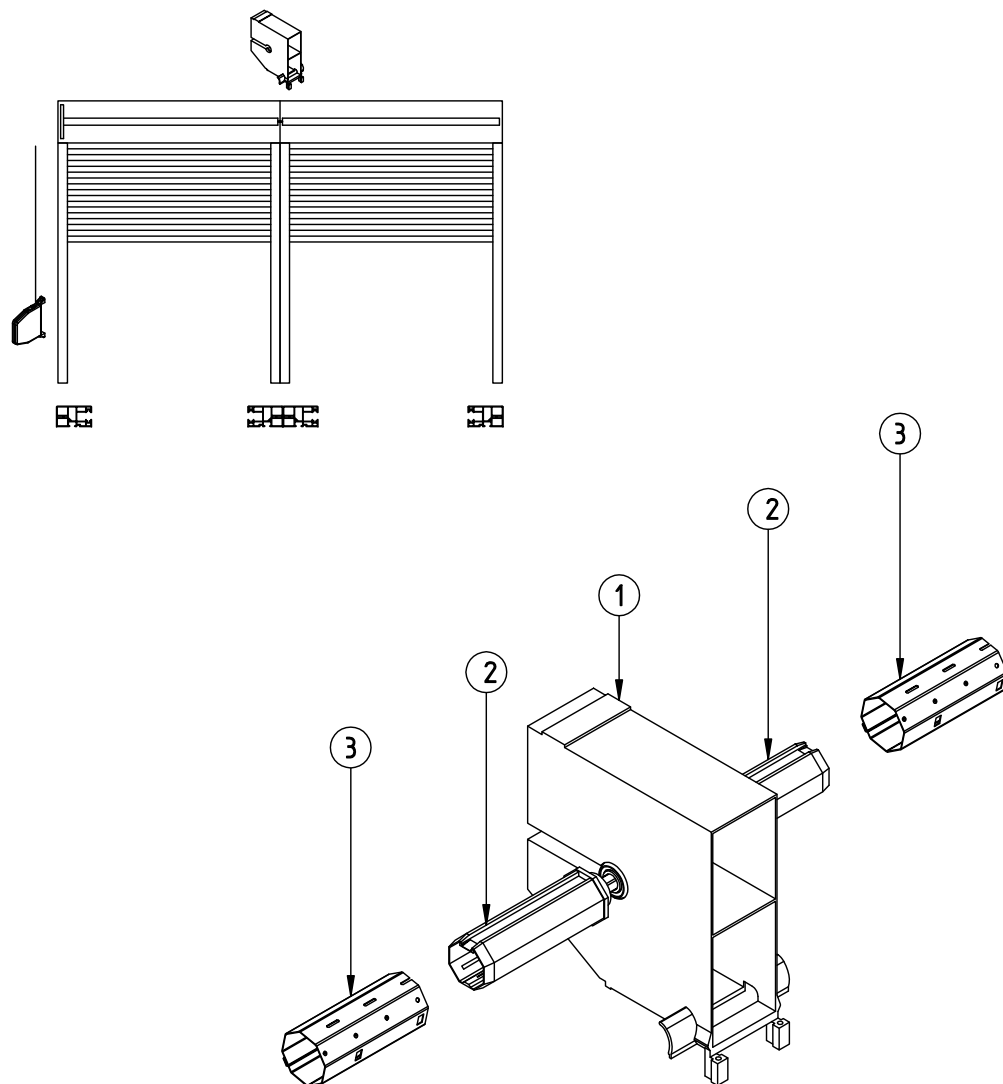

- | | | |
|---|-------|--|
| 1 | RKB2 | 160 box division for two single guides |
| | RKB3 | 200 box division for two single guides |
| 2 | RKZ34 | Roller bolt for \varnothing 40 pipe |
| | RKZ35 | Roller bolt for \varnothing 60 pipe |
| 3 | SW 40 | Octagonal pipe \varnothing 40 |
| | SW 60 | Octagonal pipe \varnothing 60 |

CC1000 Box 135
 Installation of the RKM101 division

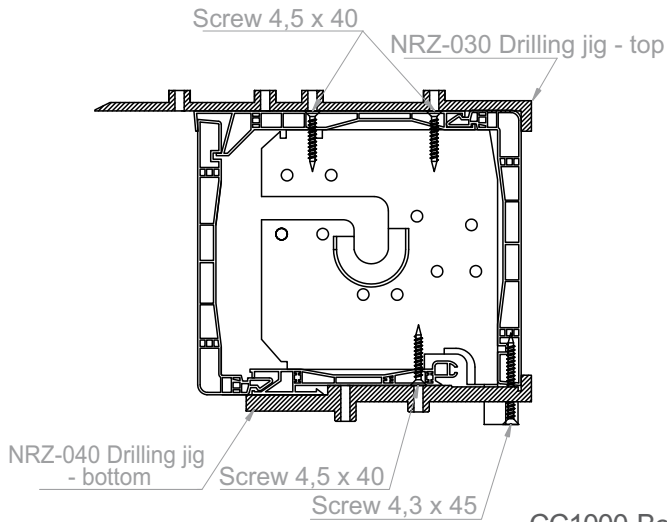

CC1000 Box 160
 Installation of the RKM201 division

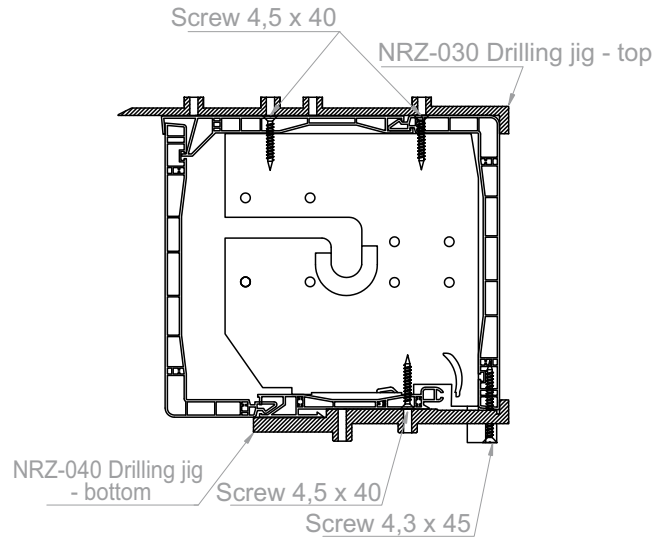

CC1000 Box 200
 Installation of the RKM301 division

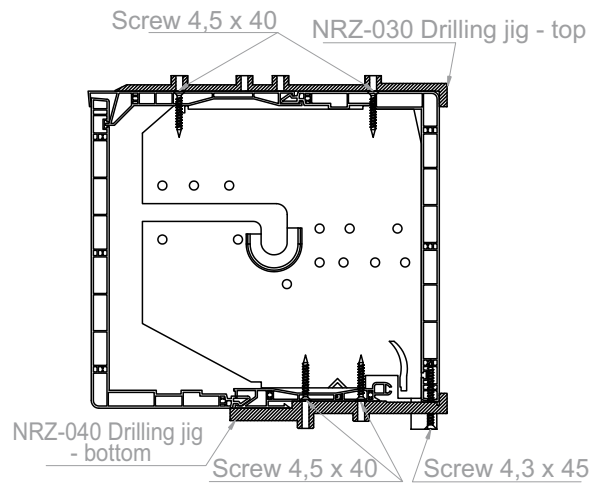

CC1000 Box 160
 Installation of the RKB2 division

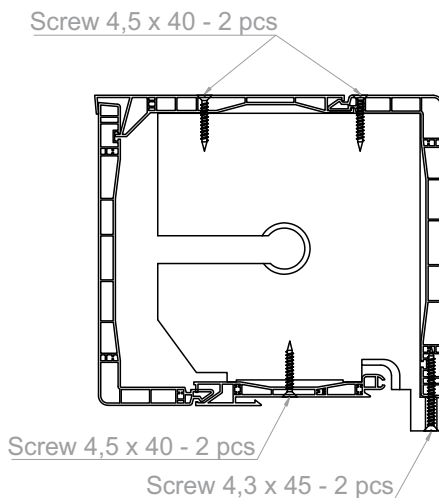

CC1000 Box 200
 Installation of the RKB3 division

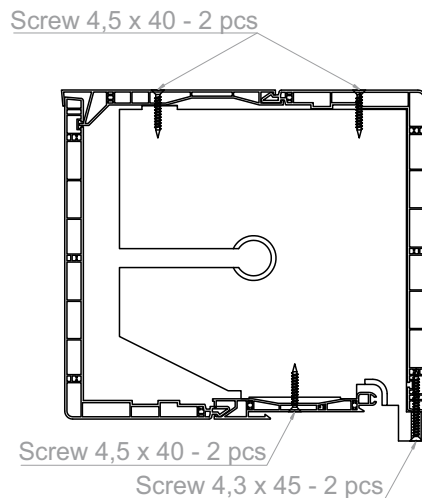

TL1000 Box 160
 Installation of the RKM201 division

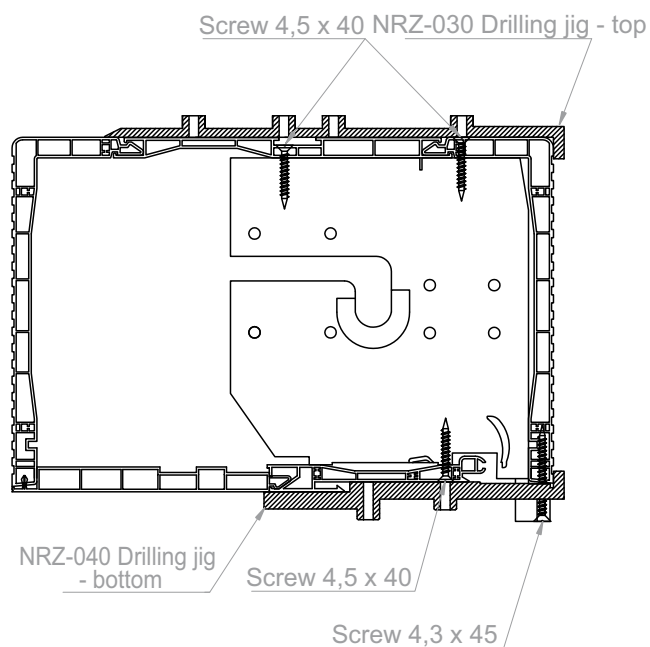

CC1000 Box 160
 Installation of the RKM201 division

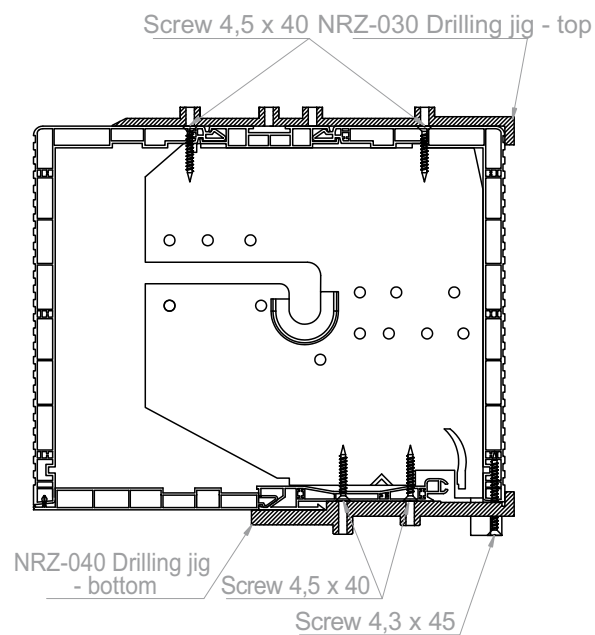

TL1000 Box 160
 Installation of the RKB2 division

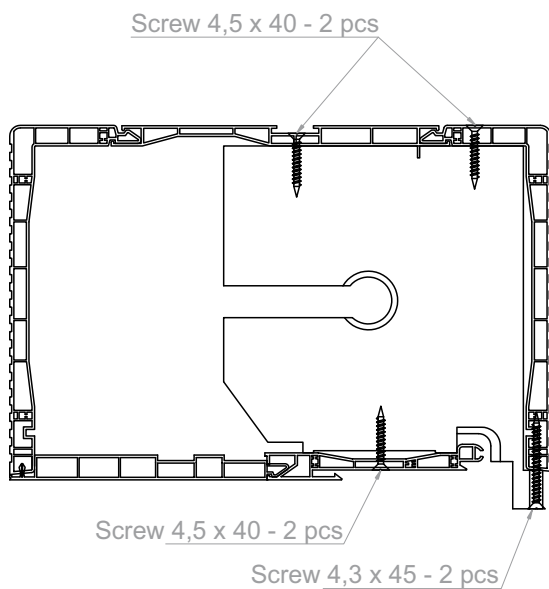

TL1000 Box 200
 Installation of the RKB3 division

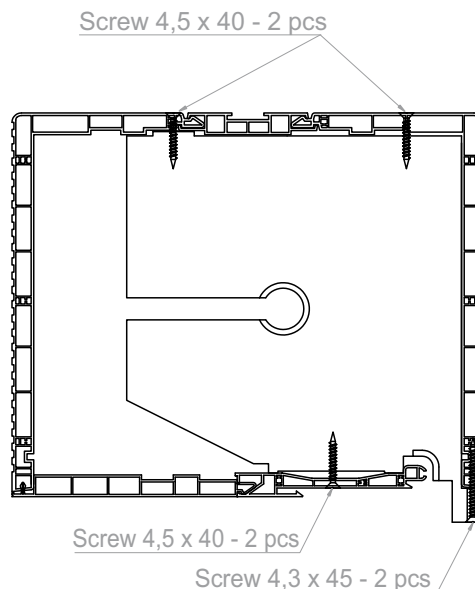

CC1000 Box 135
 Entry of the tape

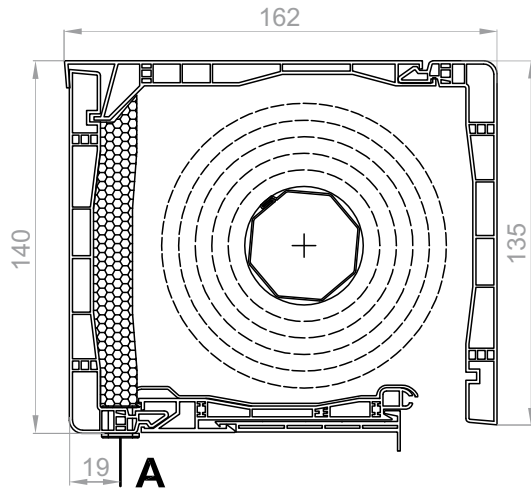

CC1000 Box 160
 Entry of the tape

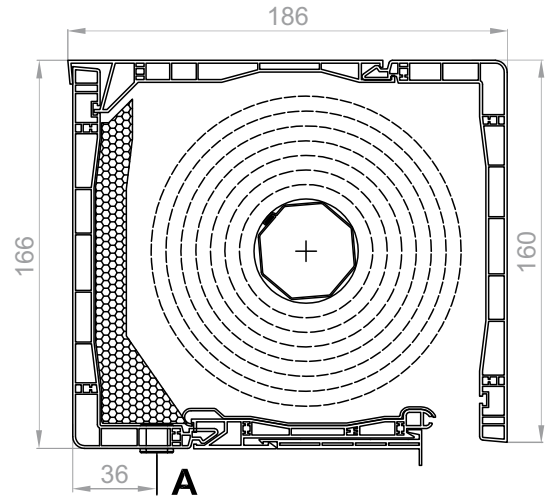

CC1000 Box 200
 Entry of the tape

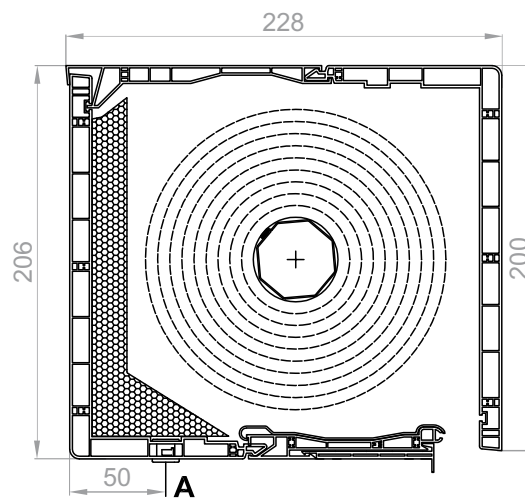

TL1000 Box 160
 Entry of the tape

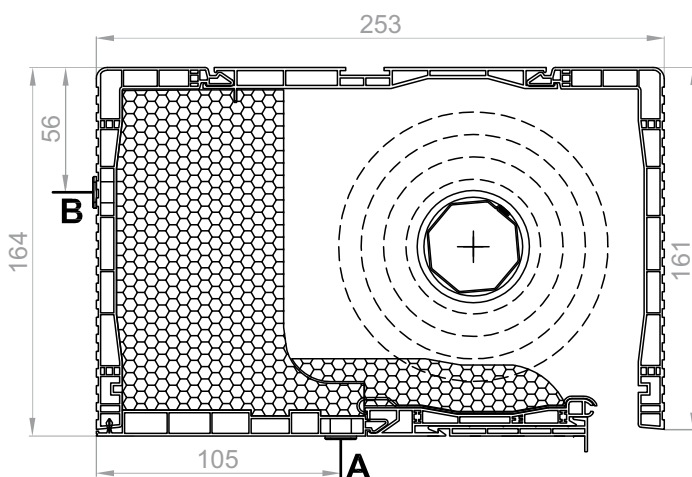

TL1000 Box 200
 Entry of the tape

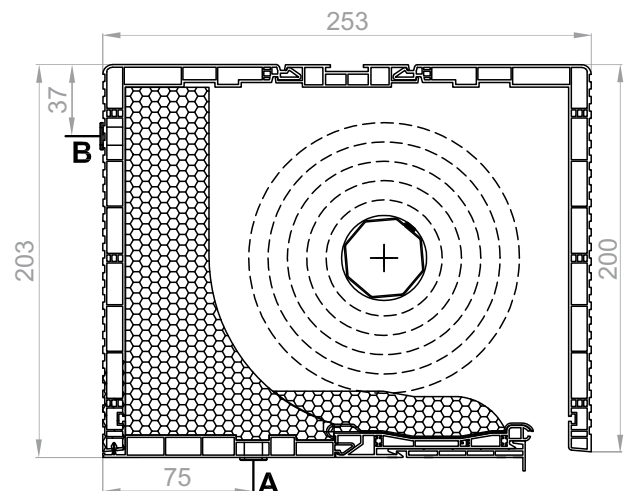

CC1000 Box 135
 Inspection cover

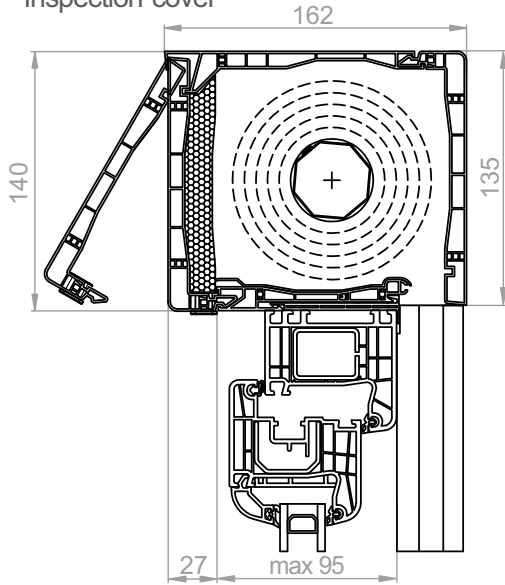

CC1000 Box 160
 Inspection cover

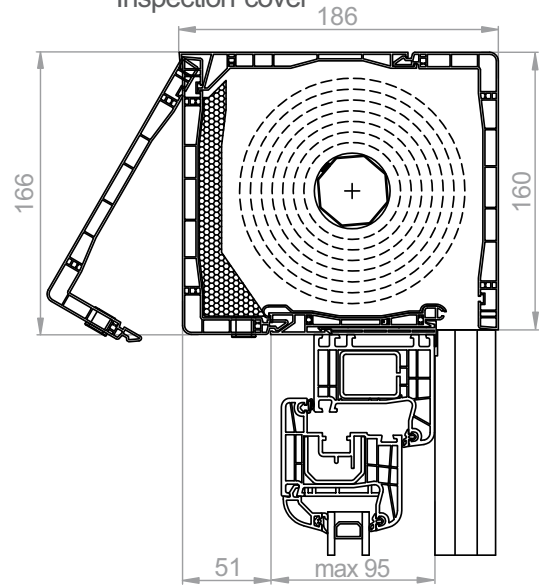

CC1000 Box 200
 Inspection cover

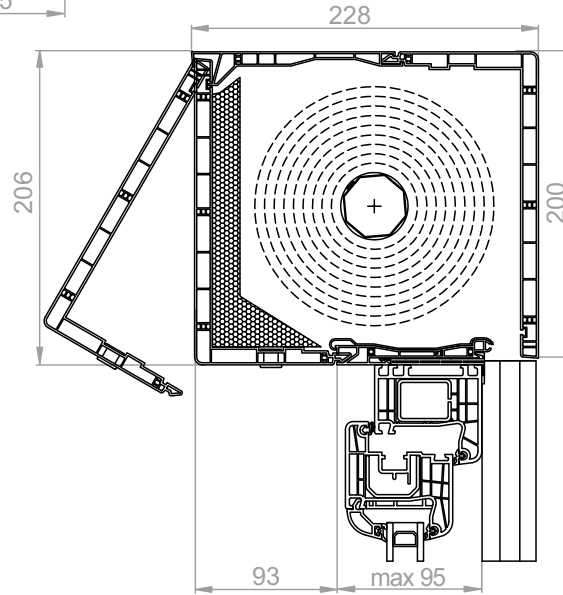

TL1000 Box 160
 Inspection cover

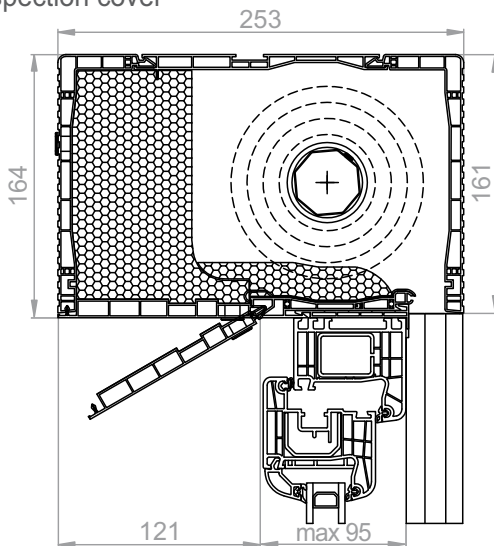

TL1000 Box 200
 Inspection cover

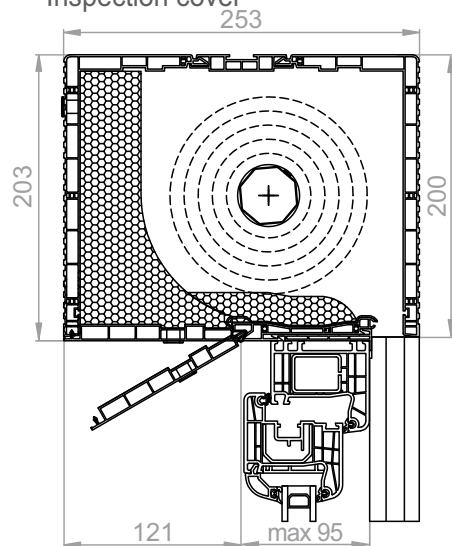

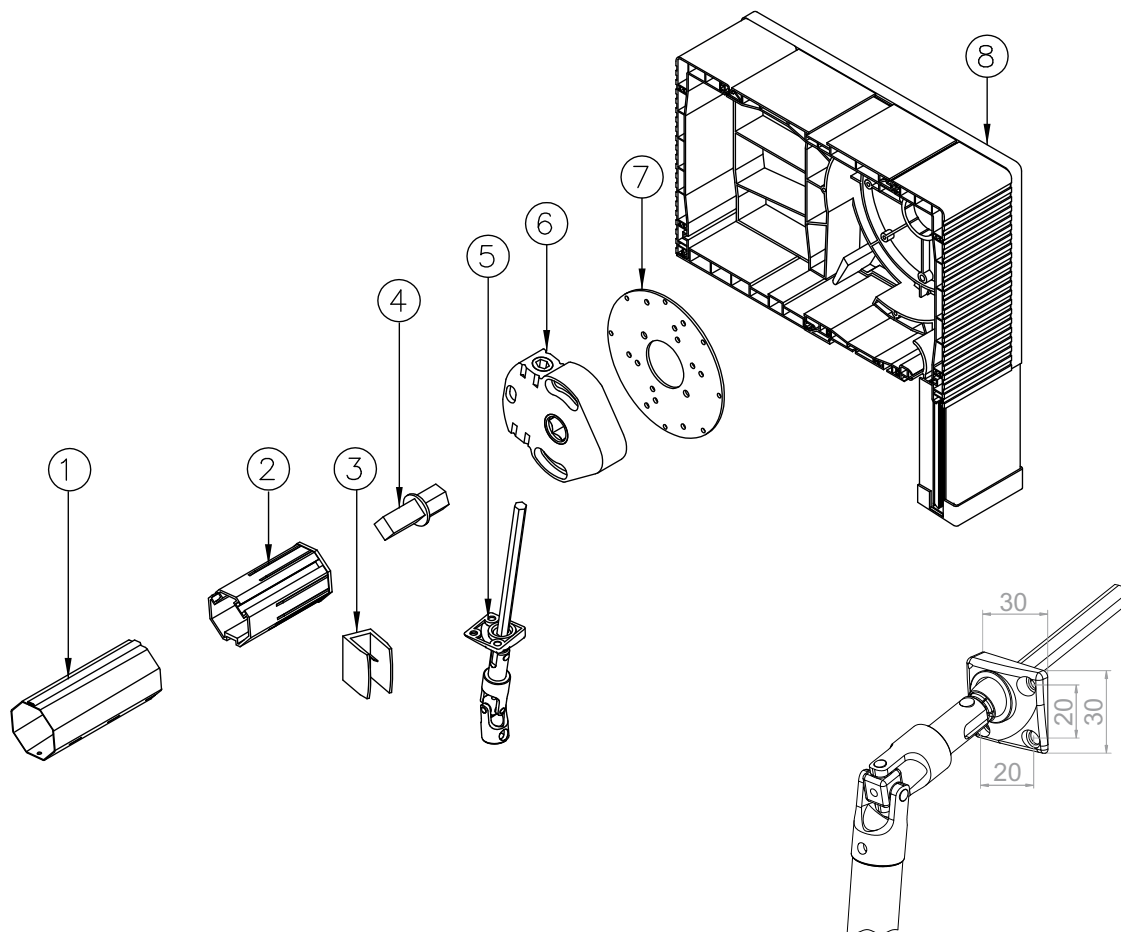

NOTE - Shutters with crank lifting mechanism drive with cardan joint cannot be equipped with automatic bolts.

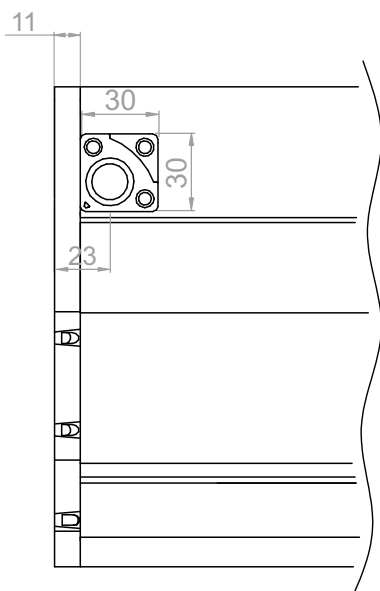

Dimensioning of the cardan mechanism output out of the shutter box

1. SW 40	Octagonal pipe \varnothing 40 mm
SW 60	Octagonal pipe \varnothing 60 mm
2. OBS-40-ACE	\varnothing 40 mounting for the ACE mechanism.
OBS-60-ACE	\varnothing 60 mounting for the ACE mechanism.
3.	Wall handle for crank - included in the crank set
4.	ACE Mounting pin - included with the ACE mechanism
5. KRH-ZF	Cardan 165 with crank 1430 mm
6. ACE-1-8 MAŁY	ACE 1:8 small crank mechanism
7. RKZ56	Plate for PCV box motor
8. Skrzynka PVC	(depending on CC1000, TL1000 system)

CC1000 - box 135
Crank lifting mechanism with cardan joint

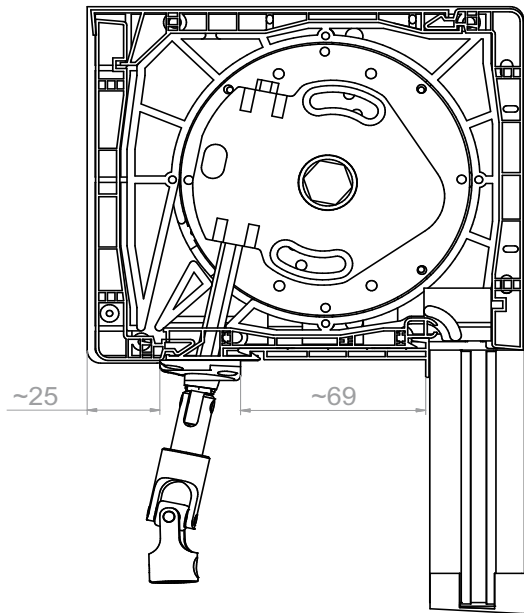

CC1000 - box 160
Crank lifting mechanism with cardan joint

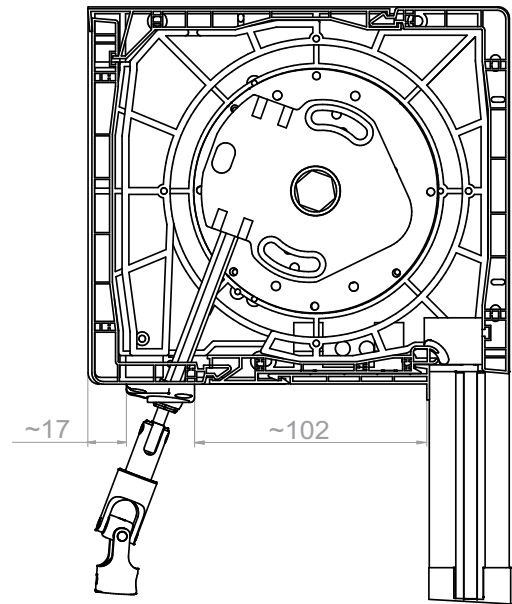

CC1000 - box 200
Crank lifting mechanism with cardan joint

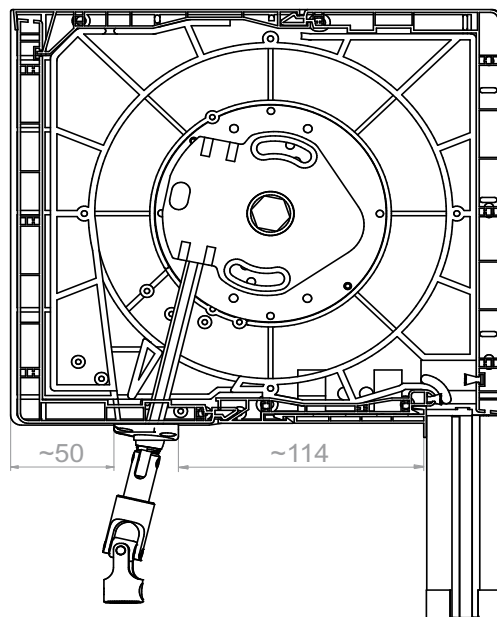

TL1000 - box 160
Crank lifting mechanism with cardan joint

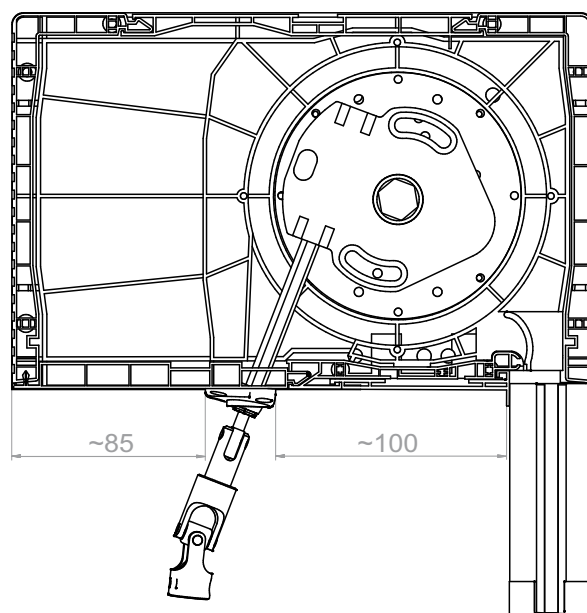

TL1000 - box 200
Crank lifting mechanism with cardan joint

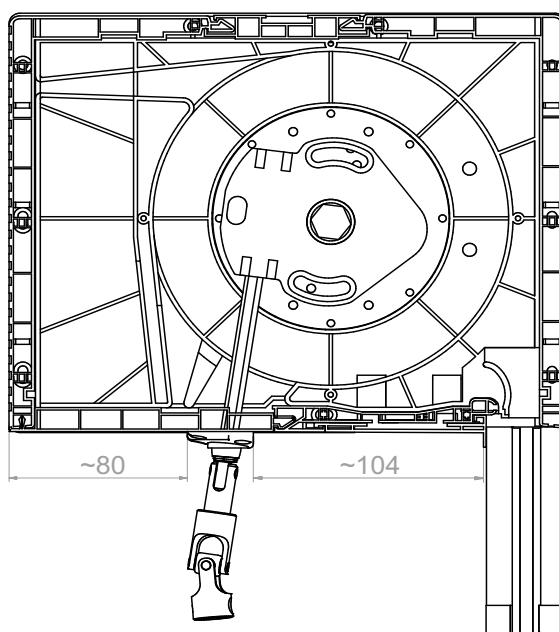

Installation of the NHK motor in CC1000 system shutter.

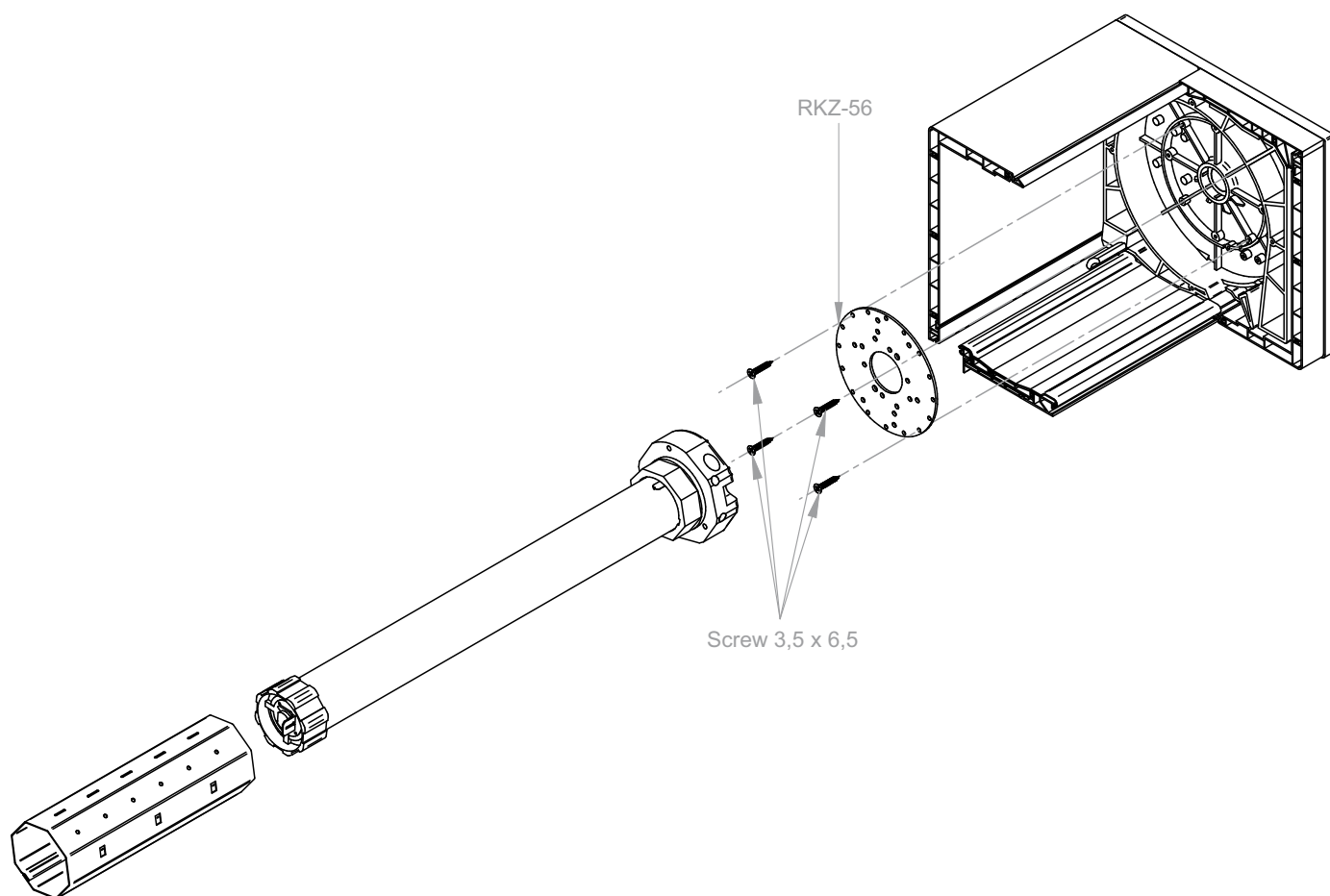

Installation of the NHK motor in TL1000 system shutter.

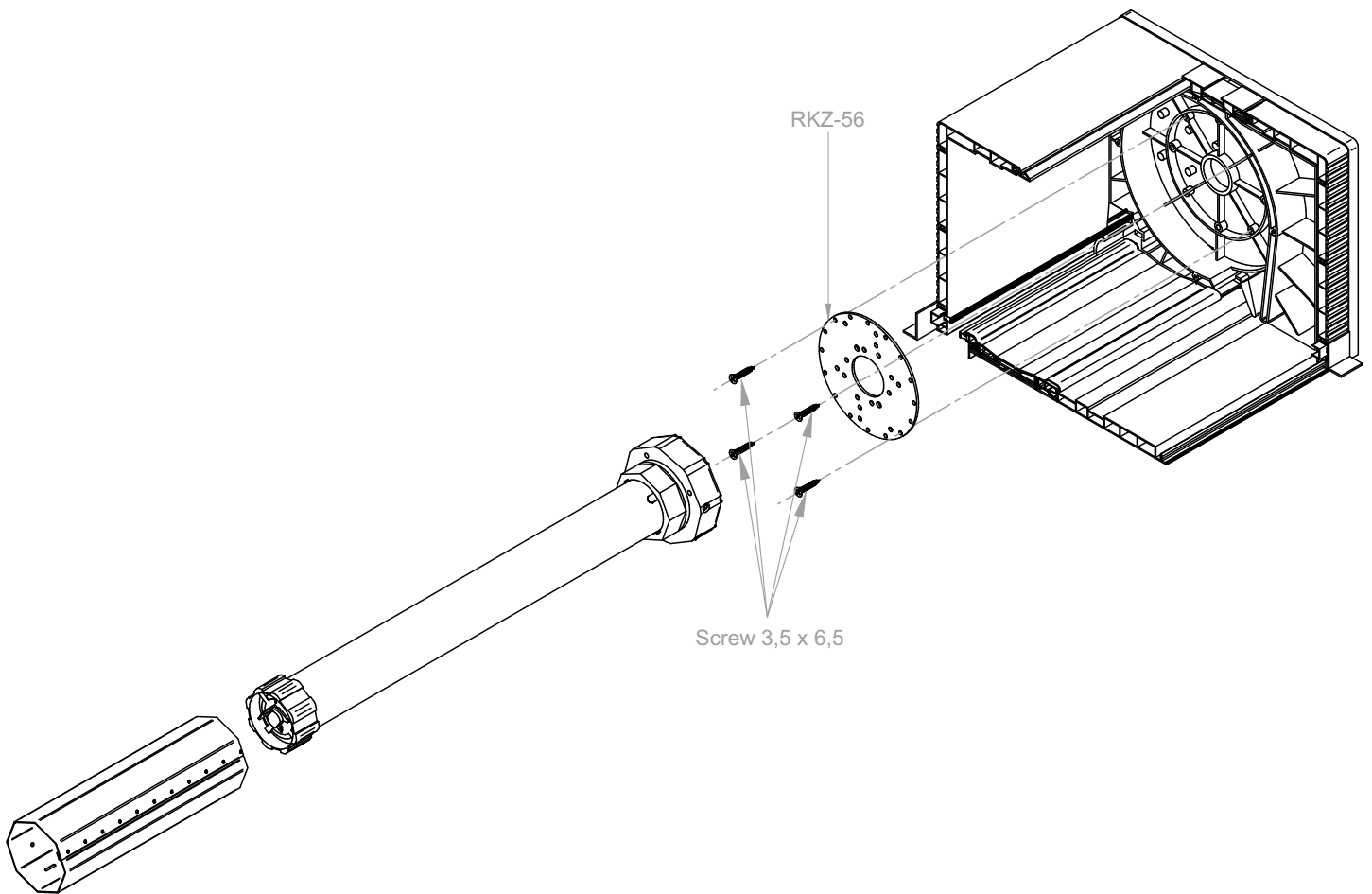

Box 160
Motor with emergency manual operation (NHK)
Output from the bottom.

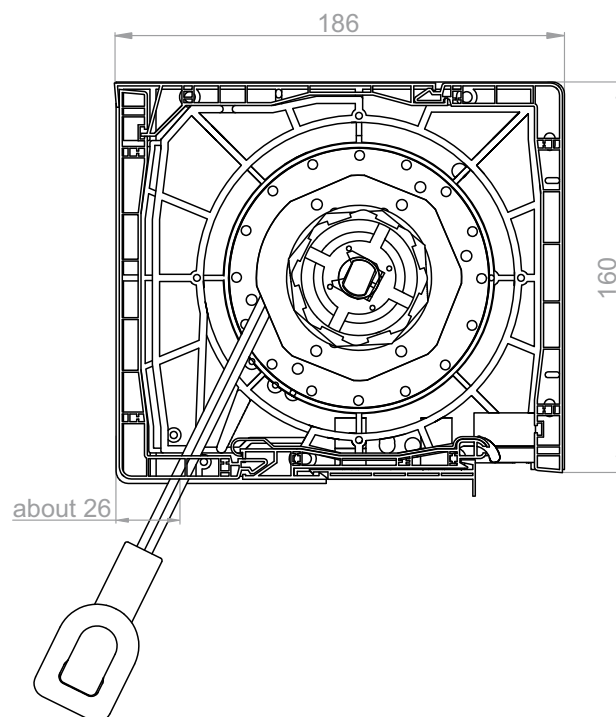

Box 200
Motor with emergency manual operation (NHK)
Output from the bottom.

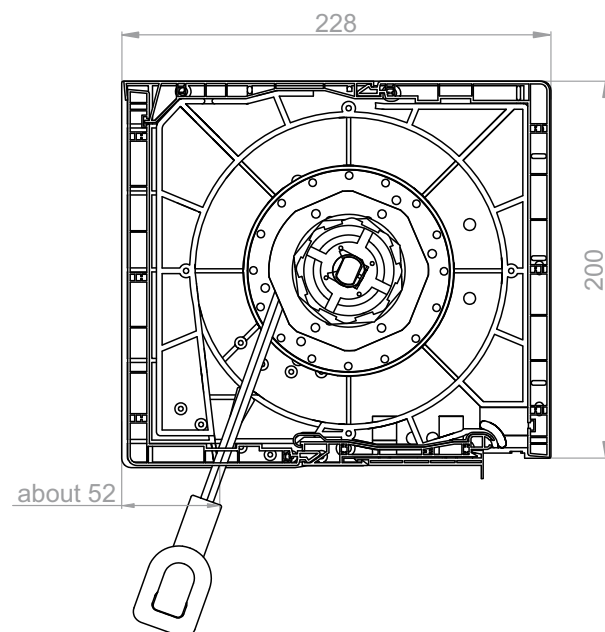

Box 160
Motor with emergency manual operation (NHK)
Output from the bottom.

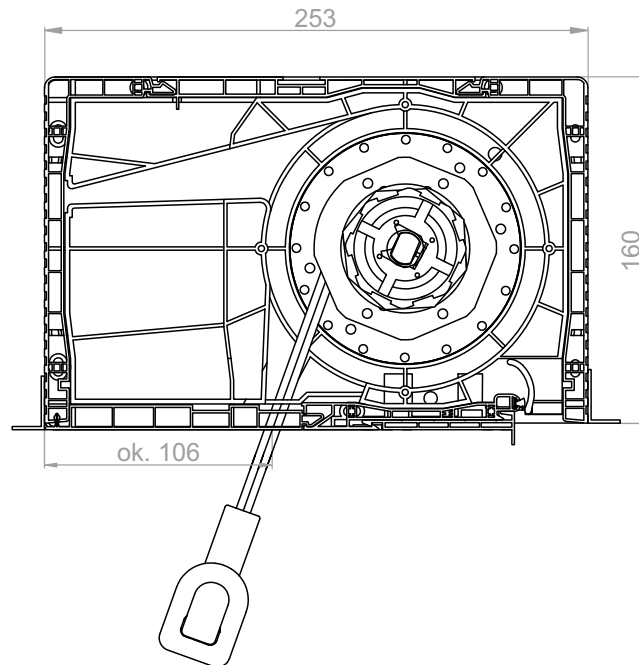

Box 200
Motor with emergency manual operation (NHK)
Output from the bottom.

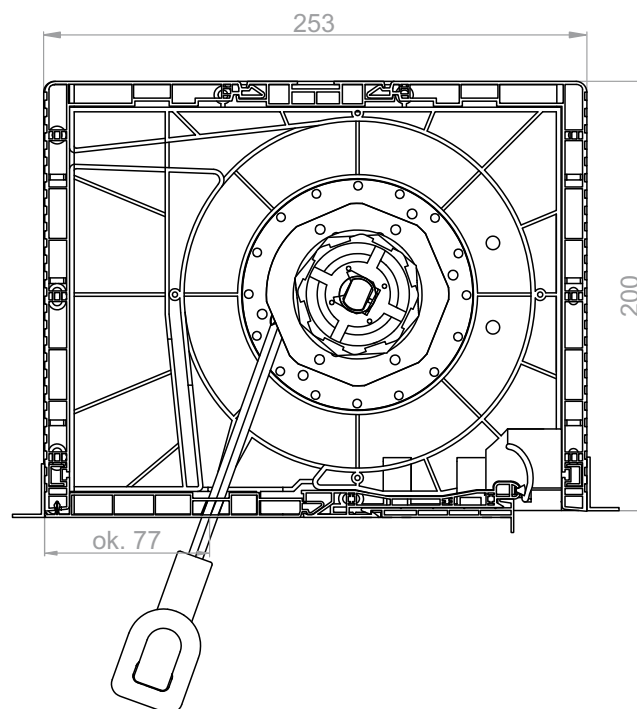

The stabilizing console is mounted as standard every 1m from the outer edge of the box side (with the use of the supplied bolts and screws).

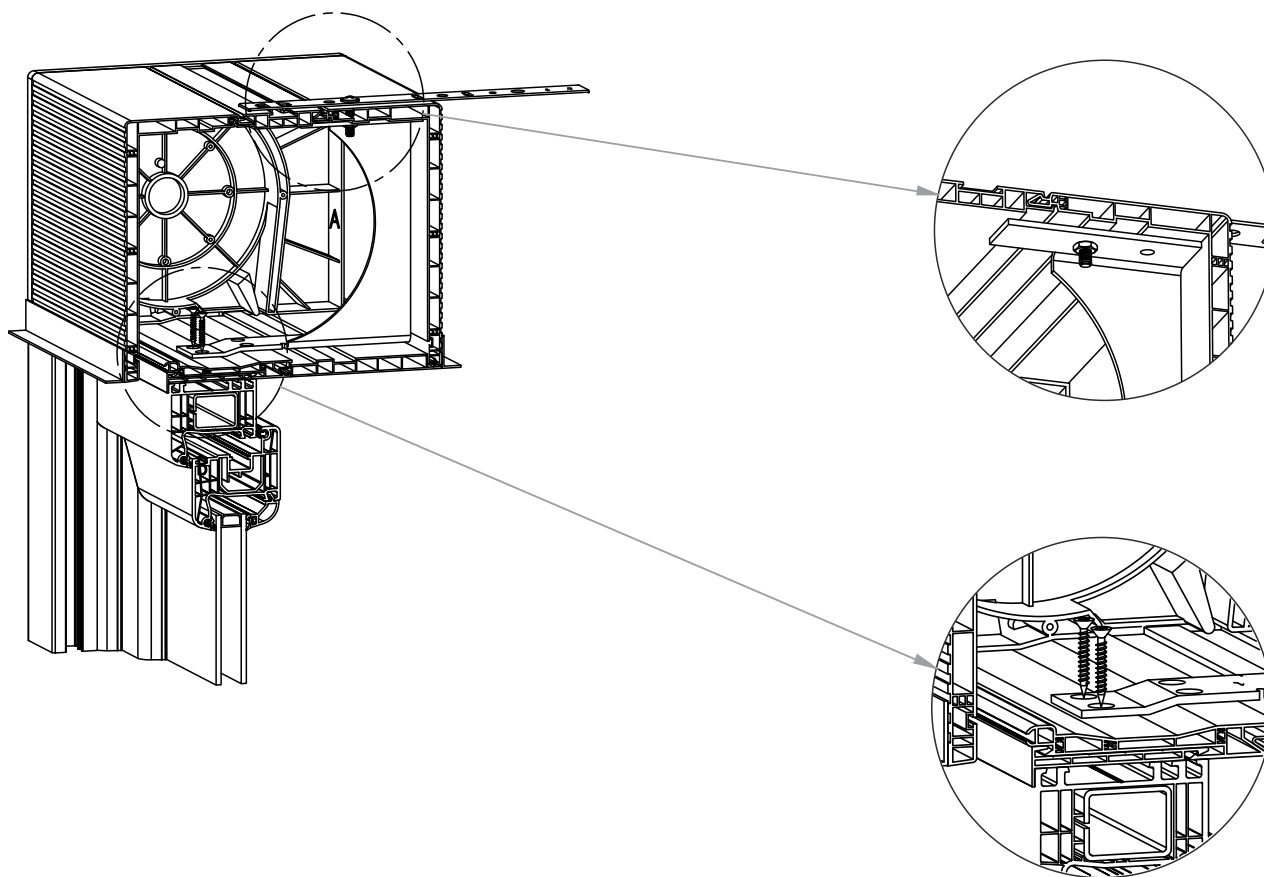

Mounting the stabilizing console in the top part with a mounting anchor.

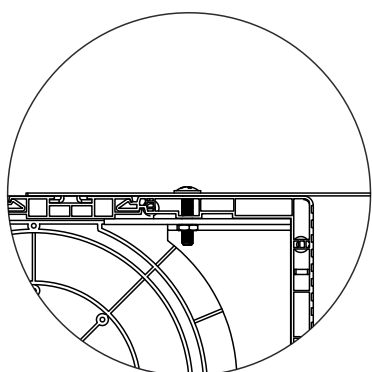

Mounting the stabilizing console in the top part without a mounting anchor.

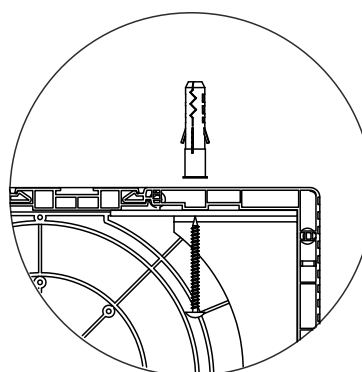

Illustrative arrangement of the stabilizing console in the TL1000 shutter box.

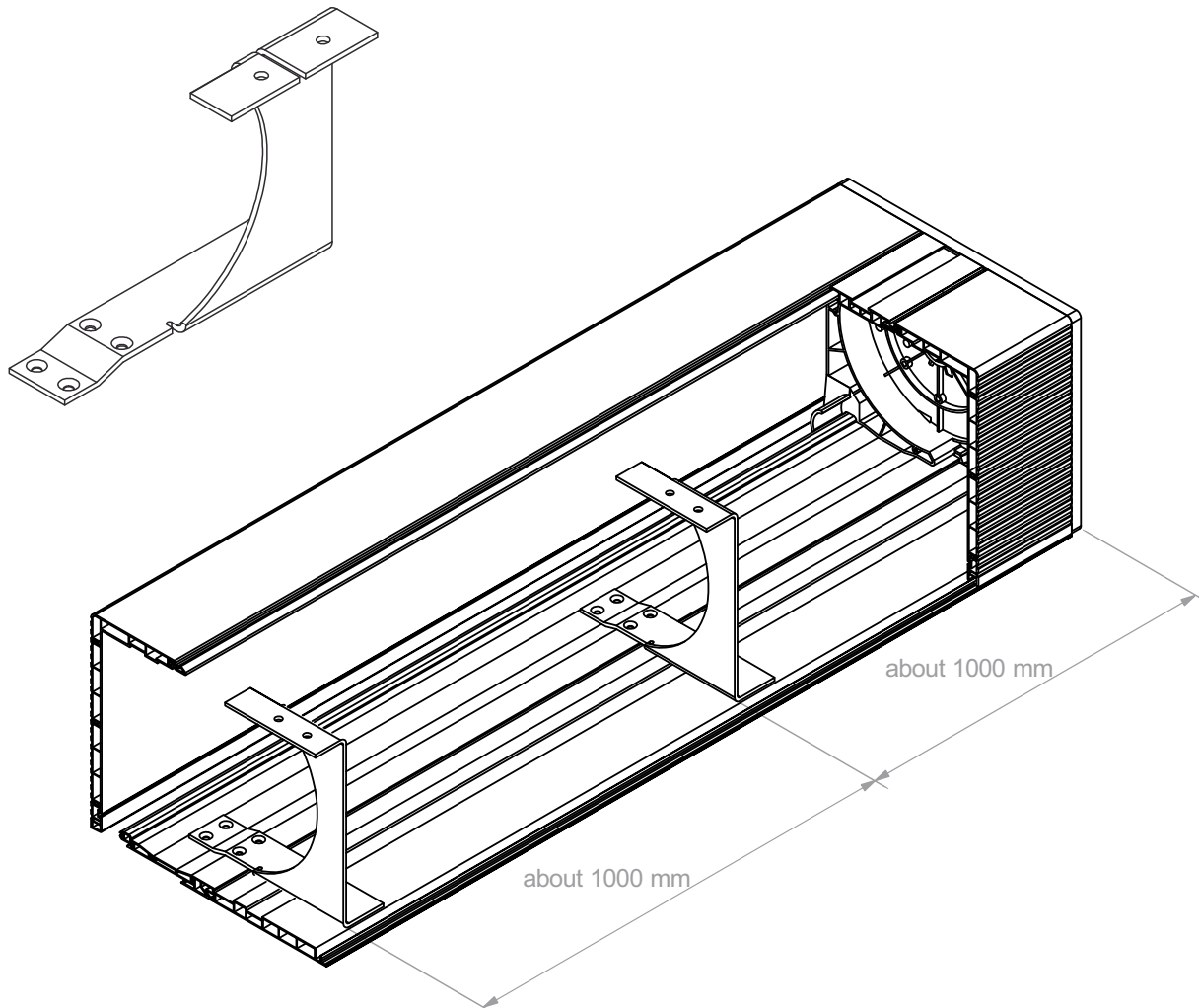

Installation of the motor in CC1000 system shutter.

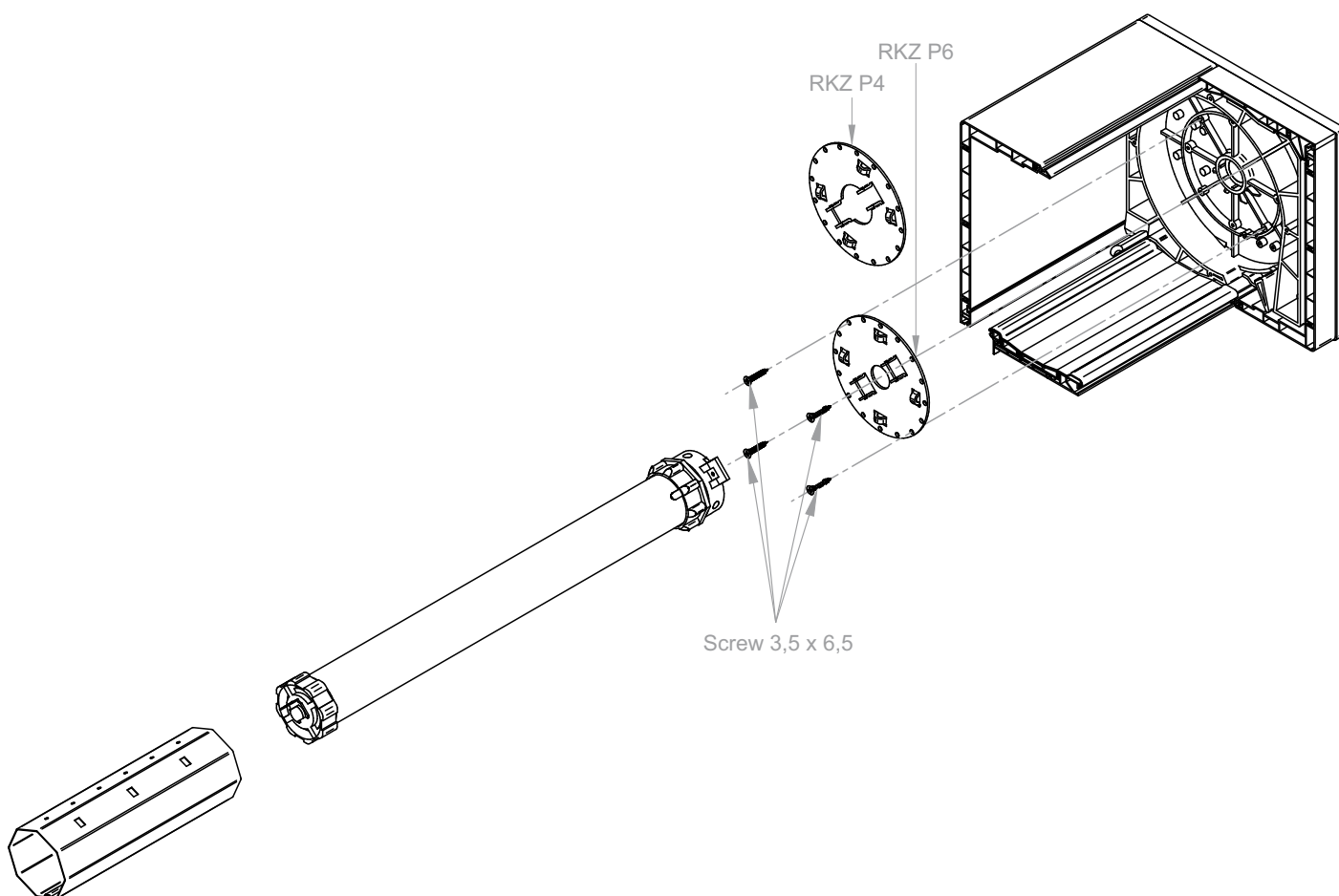

Installation of the motor in TL1000 system shutter.

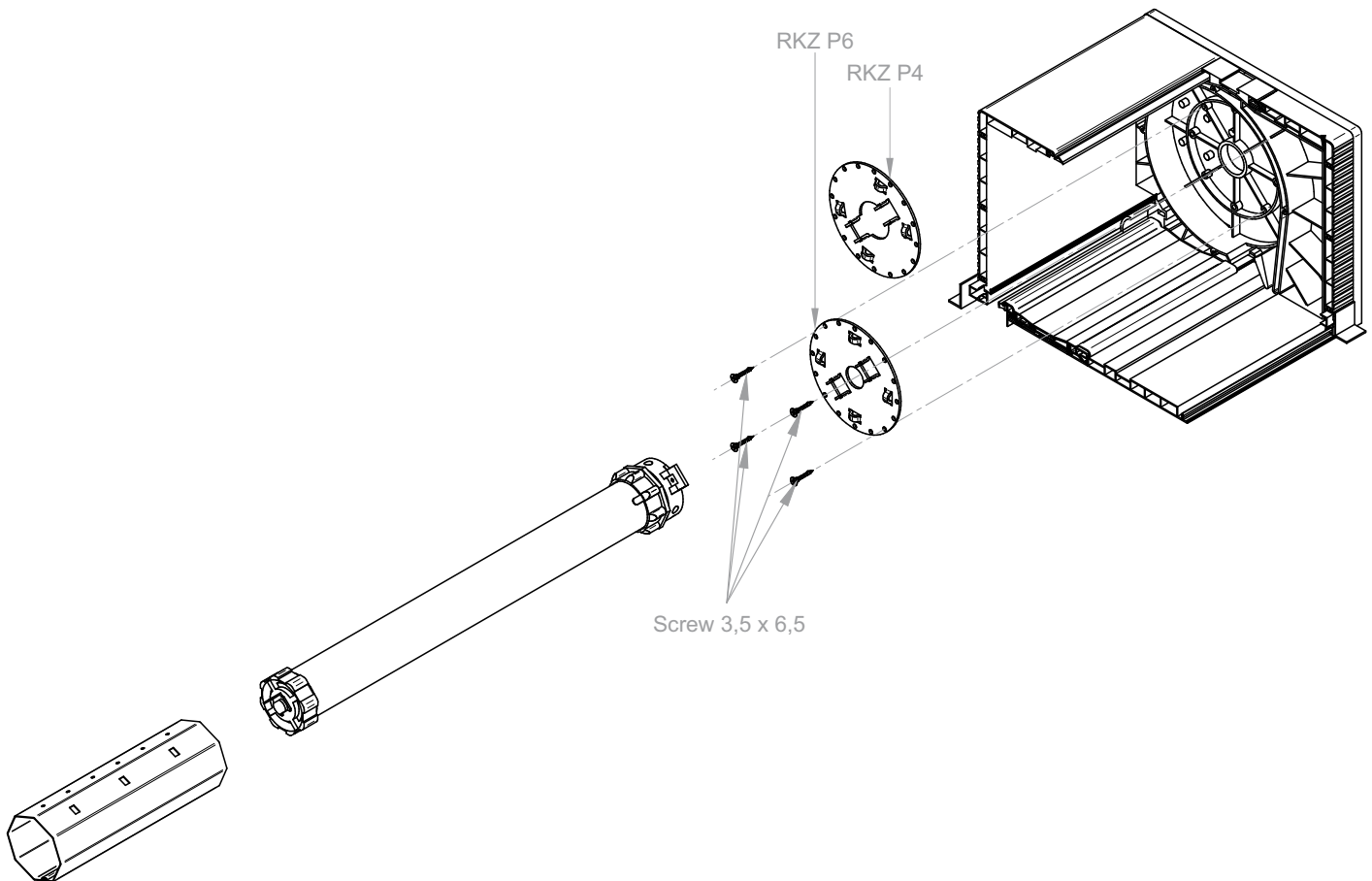

Installation of RK-18 single guide with RK-18 double guide

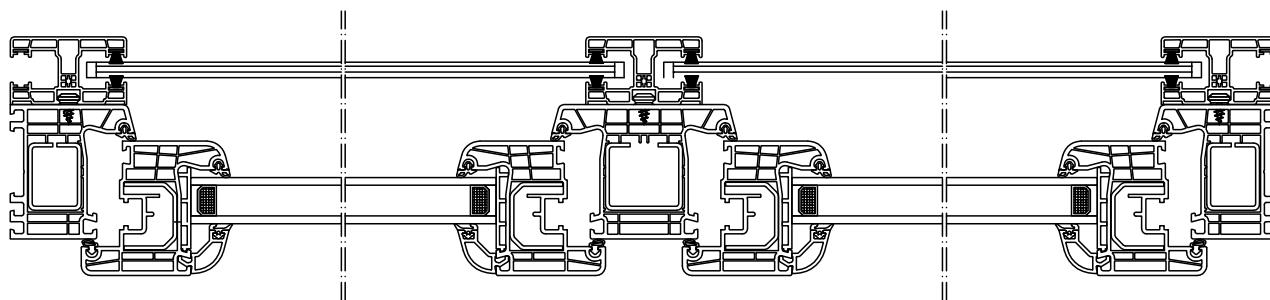

View of the RK-16 single guide with a window frame

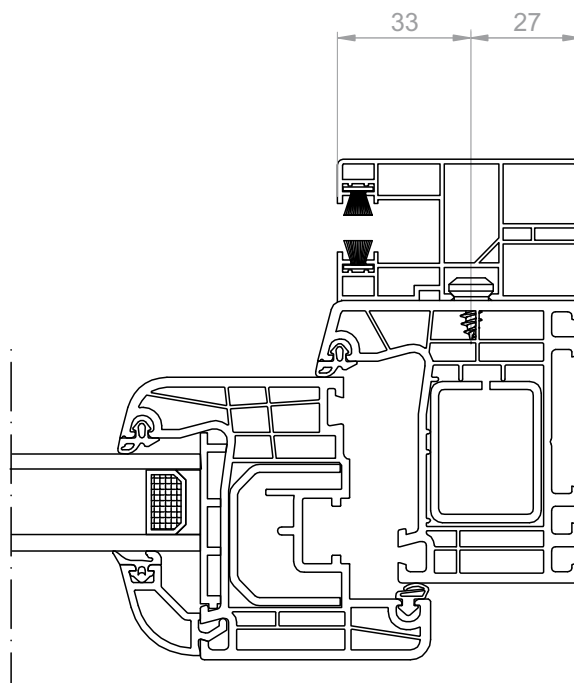

PA-39 and PA-45 curtain (including profile plugs)

Type of the box	width 0.35 - 2 m, max. area 6.5 m ²			width 0.35 - 2.5 m, max. area 6.5 m ²			width 0.35 - 3 m, max. area 6.5 m ²		
	Max. height of the shutter with box (cm)			Max. height of the shutter with box (cm)			Max. height of the shutter with box (cm)		
		with the use of automatic bolt (cm)	with the use of the blocking bracket (cm)		with the use of automatic bolt (cm)	with the use of the blocking bracket (cm)		with the use of automatic bolt (cm)	with the use of the blocking bracket (cm)
PVC	PA-39 ø 40+PZ50	PA-39 ø 40-rygiel	PA-39 ø 40-WB.	PA-39 ø 60+PZ70	PA-39 ø 60-rygiel	PA-39 ø 60-WB	PA-45 ø 60+PZ70	PA-45 ø 60-rygiel	PA-45 ø 60-WB
PSK-135 Size 135 mm	136	132	116	118*	X	X	X		X
PSK-160 Size 160 mm	202	198	202	194	190	163	138		129
PSK-200 Size 200 mm	319	319	311	311	307	272	241		219

* - There is no possibility of assembling a motor with NHK (emergency han crank) in case size 135 mm.

Note! With the shutter width of more than 2 m, use ø 60.

In addition, the box reinforcement - WSP is recommended for a width of more than 2 m. When using the reinforcement, values given in the tables should be reduced by 20 cm.

(*) it is not possible to install the NHK motor in a 135 mm box.

PZ - expansion ring from ø 40 to ø 50 or from ø 60 to ø 70.

max. thickness of the window frame 95 mm

kind of the box	height of the box	depth of the box
PSK-135	135 mm	162 mm
PSK-160	160 mm	186 mm
PSK-200	200 mm	225 mm

PA-39 and PA-45 curtain (including profile plugs)

width 0.35 - 2 m, max. area 6.5 m² | width 0.35 - 2.5 m, max. area 6.5 m² | width 0.35 - 3 m, max. area 6,5 m²

Type of the box	Max. height of the shutter with box (cm)			Max. height of the shutter with box (cm)			Max. height of the shutter with box (cm)		
		with the use of automatic bolt (cm)	with the use of the blocking bracket (cm)		with the use of automatic bolt (cm)	with the use of the blocking bracket (cm)		with the use of automatic bolt (cm)	with the use of the blocking bracket (cm)
PVC	PA-39 ø 40+PZ50	PA-39 ø 40-rygiel	PA-39 ø 40-WB.	PA-39 ø 60+PZ70	PA-39 ø 60-rygiel	PA-39 ø 60-WB	PA-45 ø 60+PZ70	PA-45 ø 60-rygiel	PA-45 ø 60-WB
160 mm	202	198	202	194	190	156	138	129	
200 mm	319	319	311	311	307	272	241	219	
200 mm+stabilizing console	300	300	311	311	307	272	241	219	
200 mm+stabilizing console	210	210	214	195	195	199	167	153	

* - Values marked by an asterisk refer to the armouring with veneer 42 Woodec Turner Oak.

Note! With the shutter width of more than 2 m, use ø 60. In addition, the box reinforcement - WSP is recommended for a width of more than 2 m. When using the reinforcement, values given in the tables should be reduced by 20 cm. For each shutter it is recommended to include SKM mounting anchors counting 40 cm from the side of the box, each subsequent anchor is installed every 50 cm. For shutters with a width of more than 1.80 m it is advisable to include stabilizing consoles. When using a stabilizing console, it is necessary to decrease the values given in the recommended box sizes: at the width of 0 - 2m - by 30 cm, width of 2.01-2.5m - by 40 cm, width of 3m and max. area of 6.5 m² - by 30 cm (concerns box 160 mm, box 200 acc. table above). PZ - expansion ring from ø 40 to ø 50 or from ø 60 to ø 70.

max. thickness of the window frame 95 mm

kind of the box	height of the box	depth of the box
PSK-160	160 mm	253 mm
PSK-200	200 mm	253 mm

(Boxes prepared for anchoring)

Dowód

Obliczanie współczynnika przenikania ciepła

Sprawozdanie z badań
Nr 13-001431-PR02
(PB-E01-06-de-02)

Zleciłodawca: **PORTOS**
ul. Ziola 71
62-800 Kalisz
Polska

Podstawy:
EN ISO 10077-2:2012-02
SG 06-obowiązujący
NB-CPDS/G06/11083 2011-09
1) doposażenie wersji naradowe (p. DIN EN)

Sprawozdanie z badań nr 13-001431-PR02 (PB-E01-06-de-02) z dnia 19.02.2015 (14 00:05 PM):

Rysunek:

Wskazówka dot. zastosowania:
Sprawozdanie z badania może być dowód współczynnika przenikania ciepła.

Zakres ważności:
Wymienione dane i wyniki odnoszą się wyłącznie do badanej i opisanej próbki. Niniejsze badanie/osoba nie jest podstawą do oceny innych materiałów lub konstrukcji, ponieważ mały wpływ na jej wyników może nastąpić w wyniku zmian.

Wskazówki dot. publikacji:
Obowiązuje Instrukcja dot. korzystania z dokumentacji z badań ift. Strona tytułowa może służyć jako streszczenie.

Treść:
Liczona wartość w sumie 5 stron i załącznik (1 strona).

Wynik:
Obliczenie współczynnika przenikania ciepła wg EN ISO 10077-2:2012-02
 $U_{ab} = 1,1 \text{ W/(m}^2\text{K)}$

Wg informacji zleciłodawcy współczynnik przenikania ciepła U_{ab} został obliczony adyabatycznie w sposób odlegający od normy EN ISO 10077-2, uwarunkowany systemem na podstawie panelu zastępczego o grubości 70 mm (zamiast 60 mm).

ift Rosenheim
02.03.2015

Manuel Demel, M.BP, Dipl.-Ing. (FH)
Deputy Head of Testing Department
Building Physics

Maurice Mayer, Dip.-Ing. (FH)
Operating Testing Officer
Building Physics

ift Rosenheim GmbH
Konradstr. 21
7430 Metzingen
Tel: +49 7141 311-300
Fax: +49 7141 311-300
www.ift-roseheim.de

Pfaffing und Gellertmann - EN ISO/IEC 17065
Institute - EN ISO/IEC 17020
Zertifizierungsstelle - EN ISO/IEC 17095
Zertifizierung Management Systeme - EN ISO/IEC 17021

Virtuelle Bau-IT
ifft
DASS

Dowód

Obliczanie współczynnika przenikania ciepła

Sprawozdanie z badań
Nr 13-001431-PR06
(PB-E01-06-de-02)

Zleciłodawca: **PORTOS**
ul. Ziola 71
62-800 Kalisz
Polska

Podstawy:
EN ISO 10077-2:2012-02
SG 06-obowiązujący
NB-CPDS/G06/11083 2011-09
1) doposażenie wersji naradowe (p. DIN EN)

Sprawozdanie z badań nr 13-001431-PR06 (PB-E01-06-de-02) z dnia 19.02.2015 (14 00:05 PM):

Rysunek:

Wskazówka dot. zastosowania:
Sprawozdanie z badania może być dowód współczynnika przenikania ciepła.

Zakres ważności:
Wymienione dane i wyniki odnoszą się wyłącznie do badanej i opisanej próbki. Niniejsze badanie/osoba nie jest podstawą do oceny innych materiałów lub konstrukcji, ponieważ mały wpływ na jej wyników może nastąpić w wyniku zmian.

Wskazówki dot. publikacji:
Obowiązuje Instrukcja dot. korzystania z dokumentacji z badań ift. Strona tytułowa może służyć jako streszczenie.

Treść:
Dowód obejmuje w sumie 5 stron i załącznik (1 strona).

Wynik:
Obliczenie współczynnika przenikania ciepła wg EN ISO 10077-2:2012-02
 $U_{ab} = 1,2 \text{ W/(m}^2\text{K)}$

Wg informacji zleciłodawcy współczynnik przenikania ciepła U_{ab} został obliczony adyabatycznie w sposób odlegający od normy EN ISO 10077-2, uwarunkowany systemem na podstawie panelu zastępczego o grubości 70 mm (zamiast 60 mm).

ift Rosenheim
02.03.2015

Manuel Demel, M.BP, Dipl.-Ing. (FH)
Deputy Head of Testing Department
Building Physics

Maurice Mayer, Dip.-Ing. (FH)
Operating Testing Officer
Building Physics

ift Rosenheim GmbH
Konradstr. 21
7430 Metzingen
Tel: +49 7141 311-300
Fax: +49 7141 311-300
www.ift-roseheim.de

Pfaffing und Gellertmann - EN ISO/IEC 17065
Institute - EN ISO/IEC 17020
Zertifizierungsstelle - EN ISO/IEC 17095
Zertifizierung Management Systeme - EN ISO/IEC 17021

Virtuelle Bau-IT
ifft
DASS

Dowód

Obliczanie współczynnika przenikania ciepła

Sprawozdanie z badań
Nr 13-001431-PR03
(PB-E01-06-de-02)

Zleciłodawca: **PORTOS**
ul. Ziola 71
62-800 Kalisz
Polska

Podstawy:
EN ISO 10077-2:2012-02
SG 06-obowiązujący
NB-CPDS/G06/11083 2011-09
1) doposażenie wersji naradowe (p. DIN EN)

Sprawozdanie z badań nr 13-001431-PR03 (PB-E01-06-de-02) z dnia 19.02.2015 (14 00:05 PM):

Rysunek:

Wskazówka dot. zastosowania:
Sprawozdanie z badania może być dowód współczynnika przenikania ciepła.

Zakres ważności:
Wymienione dane i wyniki odnoszą się wyłącznie do badanej i opisanej próbki. Niniejsze badanie/osoba nie jest podstawą do oceny innych materiałów lub konstrukcji, ponieważ mały wpływ na jej wyników może nastąpić w wyniku zmian.

Wskazówki dot. publikacji:
Obowiązuje Instrukcja dot. korzystania z dokumentacji z badań ift. Strona tytułowa może służyć jako streszczenie.

Treść:
Liczona wartość w sumie 5 stron i załącznik (1 strona).

Wynik:
Obliczenie współczynnika przenikania ciepła wg EN ISO 10077-2:2012-02
 $U_{ab} = 1,2 \text{ W/(m}^2\text{K)}$

Wg informacji zleciłodawcy współczynnik przenikania ciepła U_{ab} został obliczony adyabatycznie w sposób odlegający od normy EN ISO 10077-2, uwarunkowany systemem na podstawie panelu zastępczego o grubości 70 mm (zamiast 60 mm).

ift Rosenheim
02.03.2015

Manuel Demel, M.BP, Dipl.-Ing. (FH)
Deputy Head of Testing Department
Building Physics

Maurice Mayer, Dip.-Ing. (FH)
Operating Testing Officer
Building Physics

ift Rosenheim GmbH
Konradstr. 21
7430 Metzingen
Tel: +49 7141 311-300
Fax: +49 7141 311-300
www.ift-roseheim.de

Pfaffing und Gellertmann - EN ISO/IEC 17065
Institute - EN ISO/IEC 17020
Zertifizierungsstelle - EN ISO/IEC 17095
Zertifizierung Management Systeme - EN ISO/IEC 17021

Virtuelle Bau-IT
ifft
DASS

Dowód

Obliczanie współczynnika przenikania ciepła

Sprawozdanie z badań
Nr 13-001431-PR04
(PB-E01-06-de-02)

Zleciłodawca: **PORTOS**
ul. Ziola 71
62-800 Kalisz
Polska

Podstawy:
EN ISO 10077-2:2012-02
SG 06-obowiązujący
NB-CPDS/G06/11083 2011-09
1) doposażenie wersji naradowe (p. DIN EN)

Sprawozdanie z badań nr 13-001431-PR04 (PB-E01-06-de-02) z dnia 19.02.2015 (14 00:05 PM):

Rysunek:

Wskazówka dot. zastosowania:
Sprawozdanie z badania może być dowód współczynnika przenikania ciepła.

Zakres ważności:
Wymienione dane i wyniki odnoszą się wyłącznie do badanej i opisanej próbki. Niniejsze badanie/osoba nie jest podstawą do oceny innych materiałów lub konstrukcji, ponieważ mały wpływ na jej wyników może nastąpić w wyniku zmian.

Wskazówki dot. publikacji:
Obowiązuje Instrukcja dot. korzystania z dokumentacji z badań ift. Strona tytułowa może służyć jako streszczenie.

Treść:
Dowód obejmuje w sumie 5 stron i załącznik (1 strona).

Wynik:
Obliczenie współczynnika przenikania ciepła wg EN ISO 10077-2:2012-02
 $U_{ab} = 0,95 \text{ W/(m}^2\text{K)}$

Wg informacji zleciłodawcy współczynnik przenikania ciepła U_{ab} został obliczony adyabatycznie w sposób odlegający od normy EN ISO 10077-2, uwarunkowany systemem na podstawie panelu zastępczego o grubości 70 mm (zamiast 60 mm).

ift Rosenheim
02.03.2015

Konrad Huber, dipl.-Ing. (FH)
Kierownik laboratorium badawczego
fizyka budowlana

Maurice Mayer, Dip.-Ing. (FH)
Kierujący inżynier
fizyka budowlana

ift Rosenheim GmbH
Konradstr. 21
7430 Metzingen
Tel: +49 7141 311-300
Fax: +49 7141 311-300
www.ift-roseheim.de

Pfaffing und Gellertmann - EN ISO/IEC 17065
Institute - EN ISO/IEC 17020
Zertifizierungsstelle - EN ISO/IEC 17095
Zertifizierung Management Systeme - EN ISO/IEC 17021

Virtuelle Bau-IT
ifft
DASS

